Assessment of AOCS in-orbit performance during Rosetta flyby at asteroid Steins

Mathias Lauer

Flight Dynamics / Interplanetary Mission Support Section
(ESA / ESOC / OPS-GFI)

Overview

Background:

- Rosetta: Mission Milestones / Spacecraft
- Steins Flyby: Geometry / Scenario

Approach Navigation:

- Strategy
- Image Processing
- Steins Optical Measurements: Results / Statistics

Autonomous Tracking during Flyby:

- Principle
- Orbit/Attitude Reconstruction
- Camera Tracking Performance
- S/C Pointing Performance

Rosetta Mission Milestones

2004/03/03	Launch from Kourou with Ariane 5
2005/03/04	1 st Earth swingby at 1954 km perigee altitude
2007/02/25	Mars swingby at 249 km pericentre altitude
2007/11/13	2 nd Earth swingby at 5295 km perigee altitude
2008/09/05	Asteroid Steins flyby at 18:39 UTC at 800 km distance
2009/11/13	3 rd Earth swingby at 2481 km perigee altitude
2010/07/10	Asteroid Lutetia flyby
2011/01/23	Orbit correction manoeuvre of 788 m/s
2014/05/22	Rendezvous with comet Churyumov-Gerasimenko, with orbit manoeuvre of 793 m/s

Rosetta Spacecraft

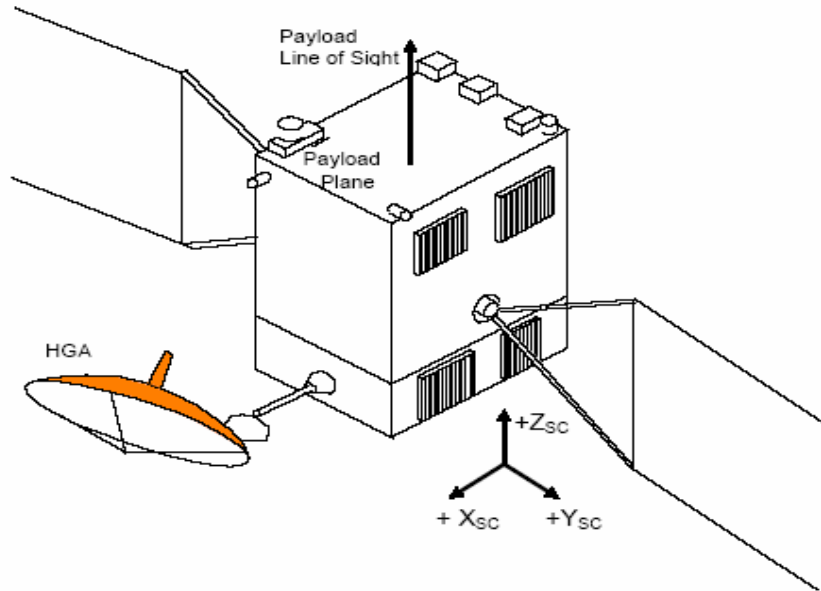

Geometry:

Box 2.0 m x 2.1 m x 2.6

2 Solar arrays 2.3 m x 14.4 m

Mass: 1343 kg dry and 1725 kg propellant at launch

RCS: 2x8 10N thrusters for attitude control (OCM / WOL / safe mode)

2x4 10N thrusters for orbit manoeuvres

Attitude control: 4 RW

Attitude sensors: 2 STR, 3 IMU (3 gyros & 3 acceleros), 4 SAS

Communication: articulated HGA (1.1 m radius dish), MGA, 2 LGA's

Navigation: 2 cameras (Navcam)

Payload: OSIRIS NAC & WAC cameras, ...

Rosetta Trajectory at Flyby

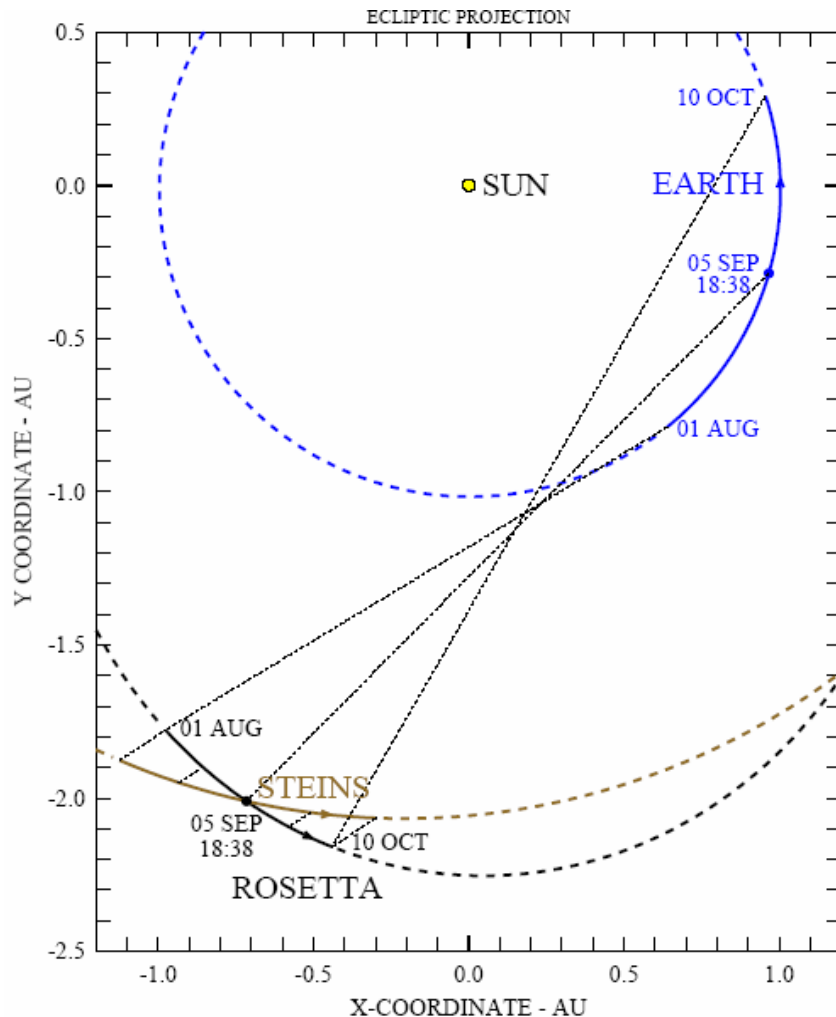

Nominal date of closest approach (CA): 2008/09/05 18:38:16 UTC

Sun distance: 2.1 AU

Earth distance: 2.4 AU

Signal delay: 20 minutes

Flyby speed: 8.616 km/s

Phase angle at approach: 38 deg

Flyby Strategy

Scientific requirement: 800 km minimum flyby distance, minimum phase angle 0 deg

Operational constraints:

- solar arrays pointing to Sun
- no extended exposure of cold face (-X) to Sun
- maximum rates and torques compliant with unit performance (STR, wheels)

Resulting pointing strategy:

- point payload boresight (+Z) always towards Steins
- flip attitude before flyby, CA – 40 min to CA – 20 min
- enter autonomous tracking 20 min before CA

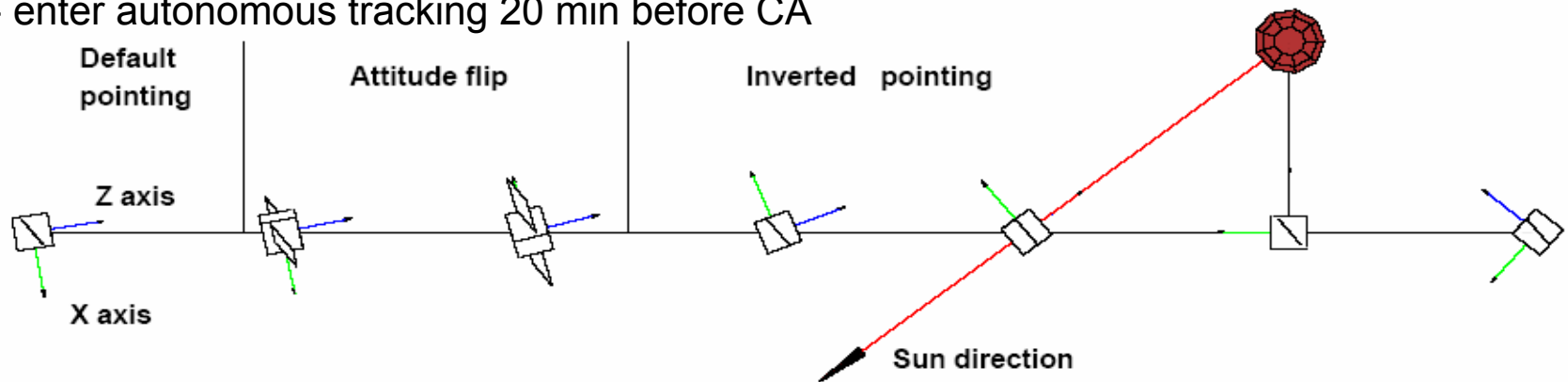

Asteroid Navigation Principle

Initial knowledge of absolute asteroid position:

- orbit determination from ground based observations
- accuracy in the order of 100 km (1σ), in each component

Navigation cycle:

- acquire images with on-board cameras and reduce to optical measurements: inertial line-of-sight from S/C to asteroid
- improve knowledge of relative asteroid position in target plane (knowledge of relative position perpendicular to target plane, i.e. equivalent to flyby time, can not be improved from optical measurements)
- determine and execute orbit manoeuvre to guide the S/C towards target (i.e. 800 km flyby distance and 0 deg minimum phase angle)

5 Navigation cycles were allocated for Steins navigation

Asteroid Steins / Brightness

Brightness depends on distances (asteroid \rightarrow Sun and asteroid \rightarrow S/C) and phase (angle Sun-asteroid-S/C).

Standard IAU phase function for asteroids depends on slope parameter.

Light curve: ± 0.2 mag over 6.1 hrs period

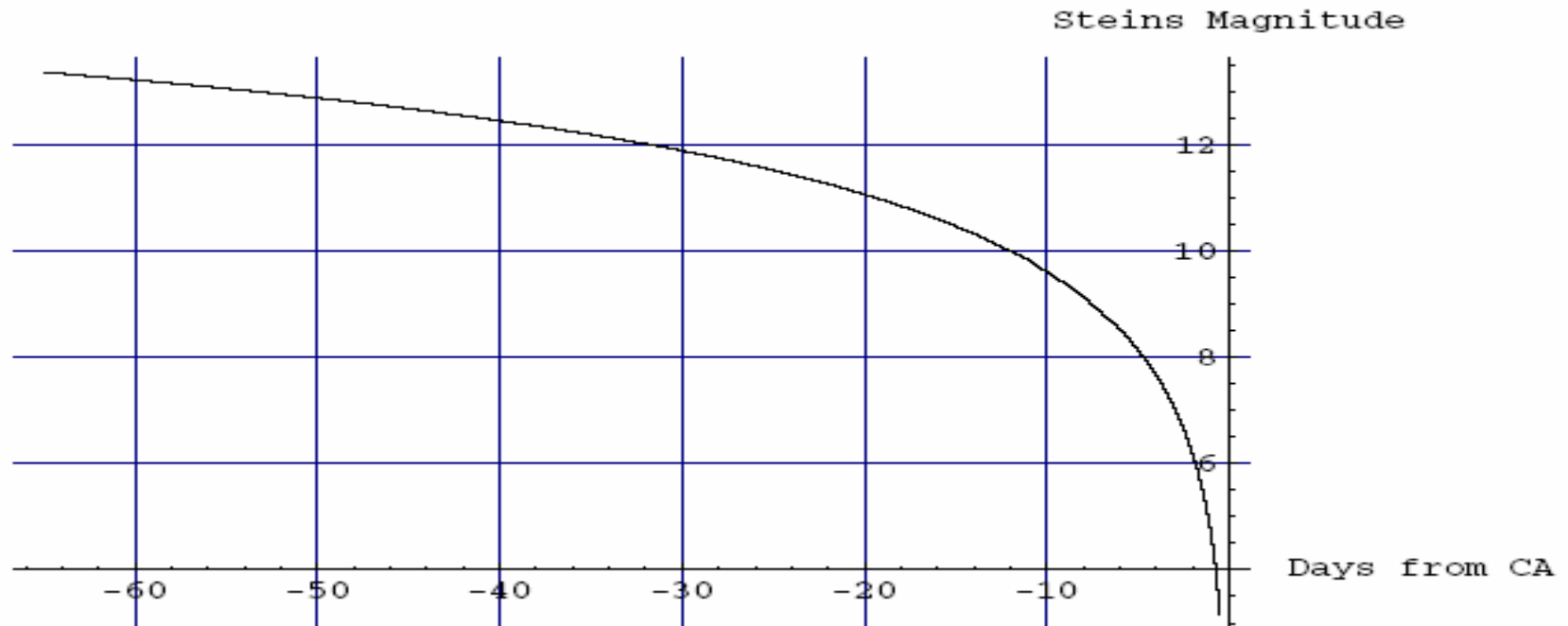

Camera Characteristics

Parameter	Navcam	Osiris/NAC
Optics type	7 lenses, 3 filters	3 mirrors off-axis, dual filter wheel
Aperture diameter	7 cm	9 cm
Field of view	5 deg x 5 deg	2.20 deg x 2.22 deg
Focal length	152.5 mm	717.4 mm
CCD	1024 x 1024 pixels	2048 x 2048 pixels
Equiv. pixel size	5 mdeg	1 mdeg
Full well	70,000 el	100,000 el
Signal resolution	12 bit: 0-4095	16 bit: 0-65535
CCD Temperature	-10 +/- 10 degC	160K to 300K

First Steins Observation from Navcam A

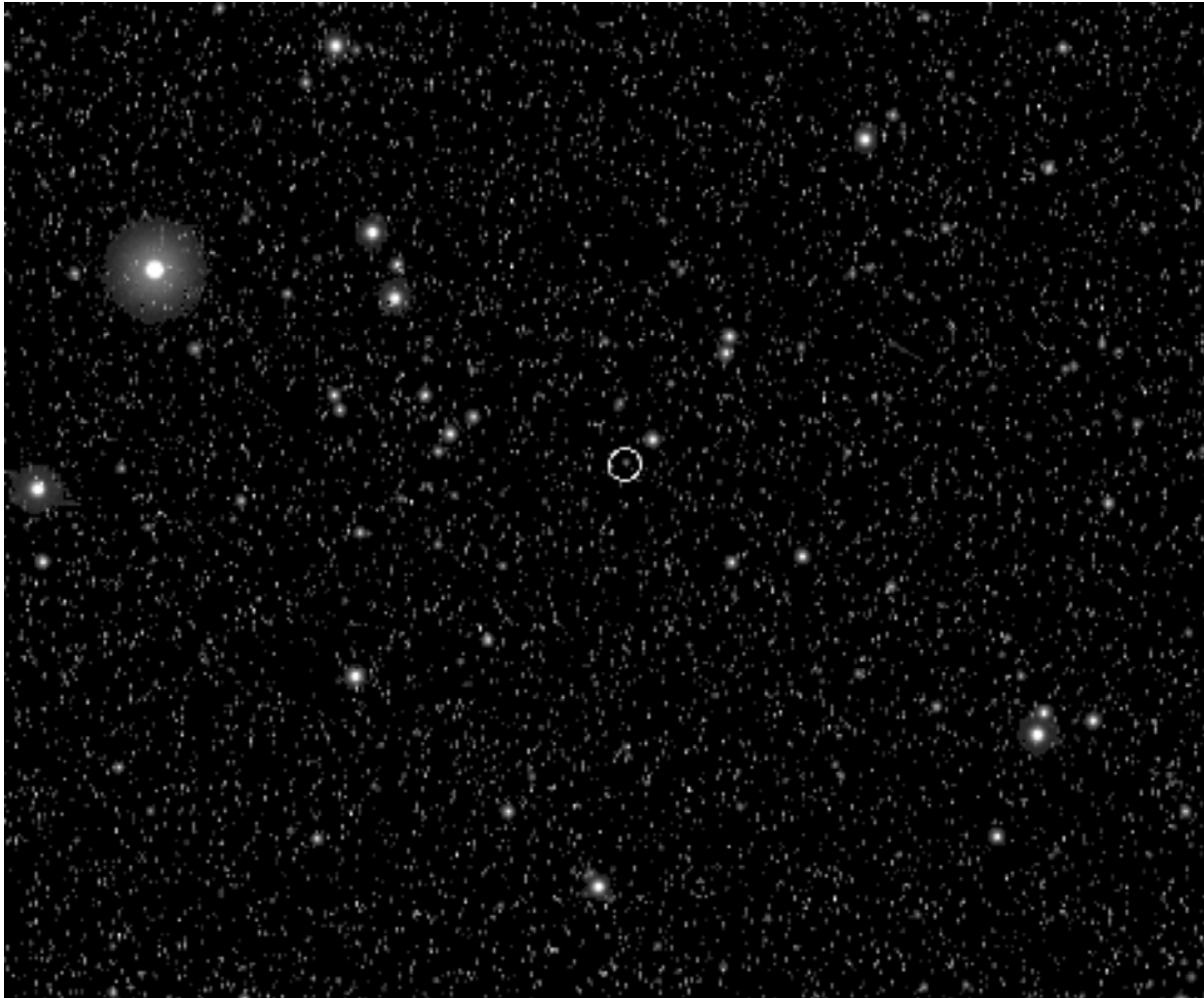

-Date: 2008/08/04,
CA - 32 days

- Image size:
ca. 3 deg x 3 deg
(205 pix/deg)

- Distance to Steins:
24.5 Mio km

- Magnitude: 12

- Exposure time: 30 s

- 'small' dots are white
pixels

Navigation Schedule

Orbit Correction Manoeuvre (OCM) Slots:

Flight Rule: error in target plane $> 2 * \text{knowledge}$, and magnitude $> 2 \text{ cm/s}$

Date	Before CA	Optical data cut-off prior to OCM	Delta-V
2008/08/14	-3 weeks	- 3 days	12.8 cm/s
2008/08/18	-8 days	- 3 days	not used
2008/09/02 15:30	-3 days	- 32 hours	not used
2008/09/04 04:00	-36 hours	- 20 hours	11.8 cm/s
2008/09/05 06:00	-12 hours	- 13 hours	not used

Optical Measurement Residuals (Navcam)

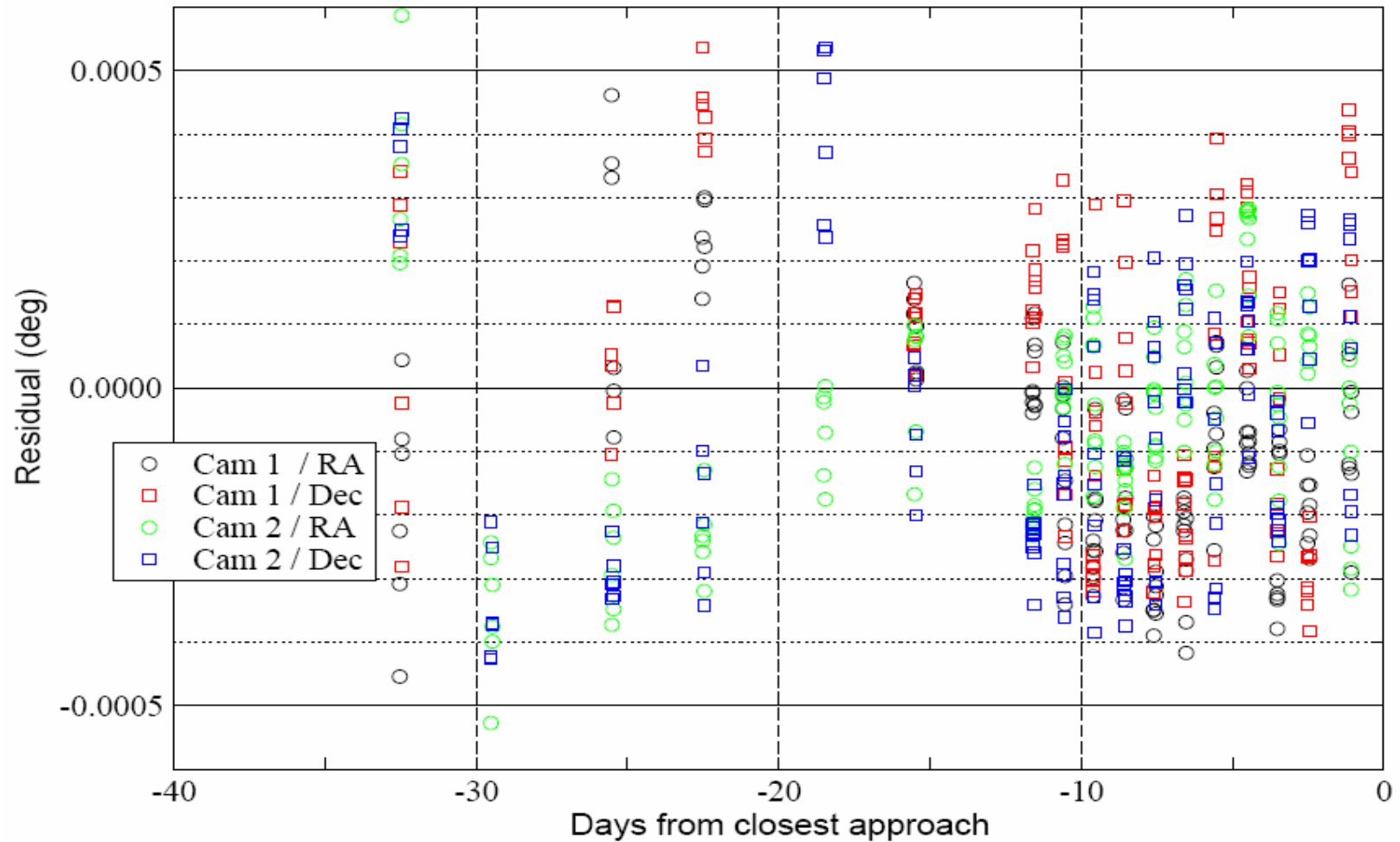

Optical Measurement Residuals (NAC)

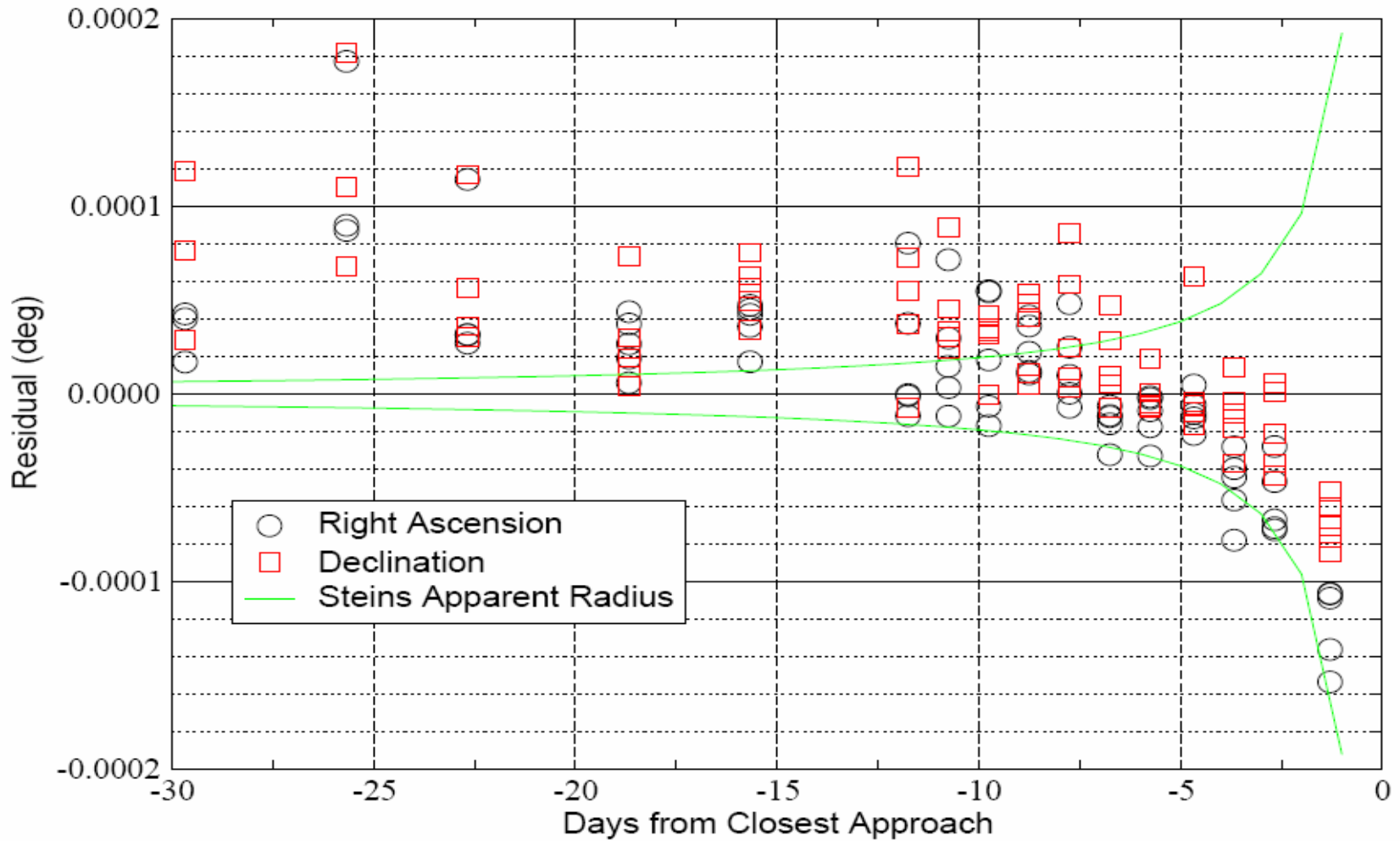

Summary of Final Approach Navigation Results

- For the first time in Europe, S/C navigation based on on-board optical measurements was performed with the flyby of Rosetta at asteroid Steins
- Accuracy of inertial line-of-sight measurements were in the order of 0.1 pixels for the Navcam (i.e. 0.5 mdeg) and Osiris/NAC camera (i.e. 0.1 mdeg).
- The target flyby distance was 800 km with 0 deg minimum phase angle.
The finally achieved flyby distance was 802.6 km with 0.27deg minimum phase angle

Autonomous Tracking during Flyby / Principle

Requirement: S/C attitude control to keep the payload boresights pointing towards the asteroid

- Phase 1: until 20 min. prior to CA
attitude following guidance profile
prepared on-ground and uploaded 12 hrs prior to CA
- Phase 2: from 20 min. prior to CA onwards
camera is operated in tracking mode:
 - periodic (2.5 s) autonomous target detection in window on CCDAOCS is operated in Asteroid Flyby Mode (AFM)
AFM estimator input: target direction in camera frame, S/C attitude
AFM estimator output:
 - tracking angle (and rate) in flyby plane,
 - inclination of flyby planeS/C attitude following guidance based on AFM estimator output

Attitude and Orbit Reconstruction

Attitude reconstruction:

- based on high resolution (8Hz) TM with on-board estimated S/C attitude derived from STR and gyro data.
- corrections applied for datation bias and jitter, stellar aberration

Orbit reconstruction:

- based on asteroid direction measurements from on-board camera; converted into inertial frame using camera alignment and attitude reconstruction
- navigation camera autonomous tracking data were considerably disturbed
- instead, Osiris/WAC images have been processed:
 - alignment performed using recent image and only central FoV
 - optical centre finding computed on ground
 - correction applied assuming Lambert sphere

Navigation Camera Tracking Performance (1)

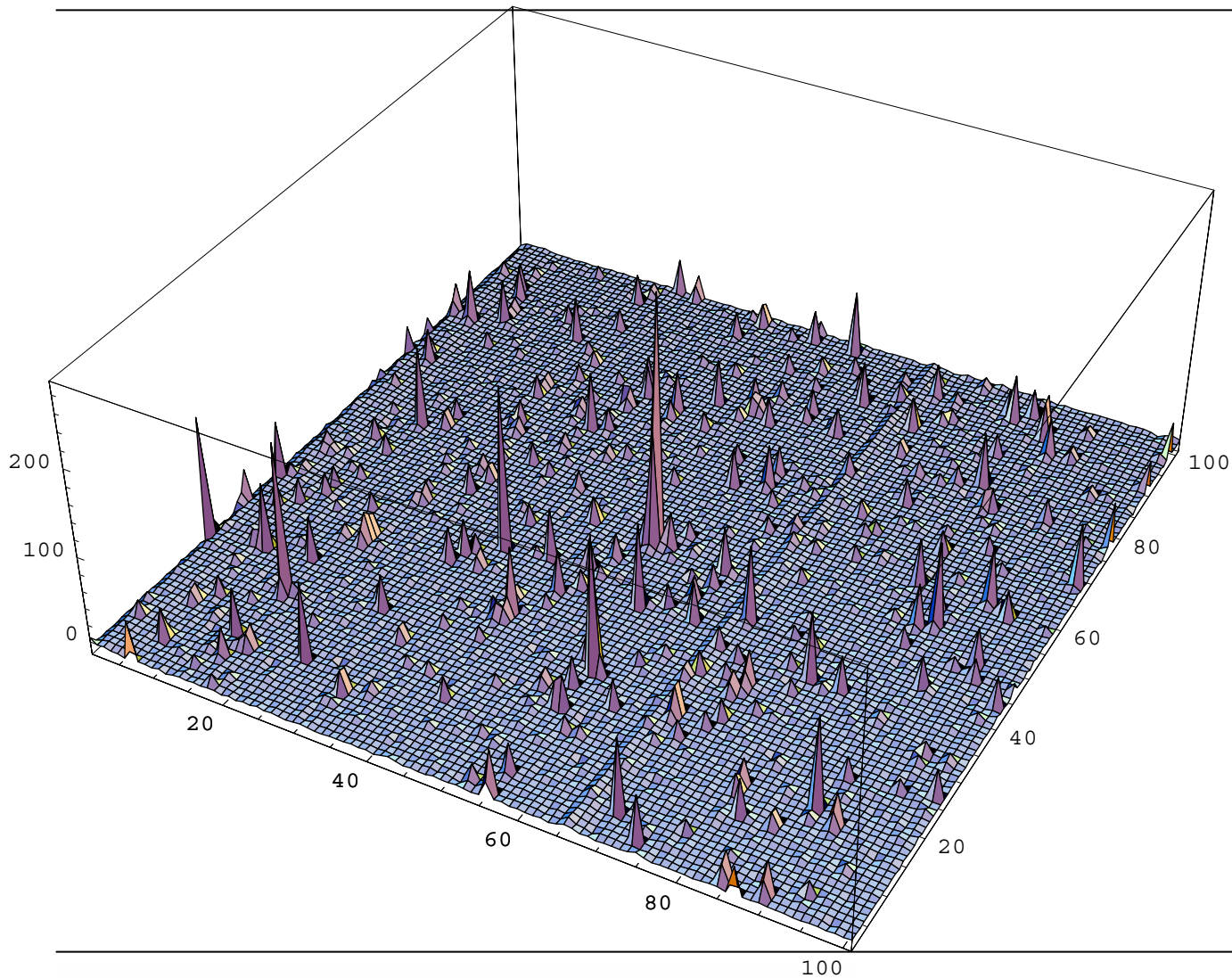

Camera image at 08:41:43 while in tracking mode.

Central peak is Steins.

Object detection failed due to presence of warm pixels.

Performance did not improve until GO/NOGO for AFM

=> Cover was modified from attenuated to not-attenuated

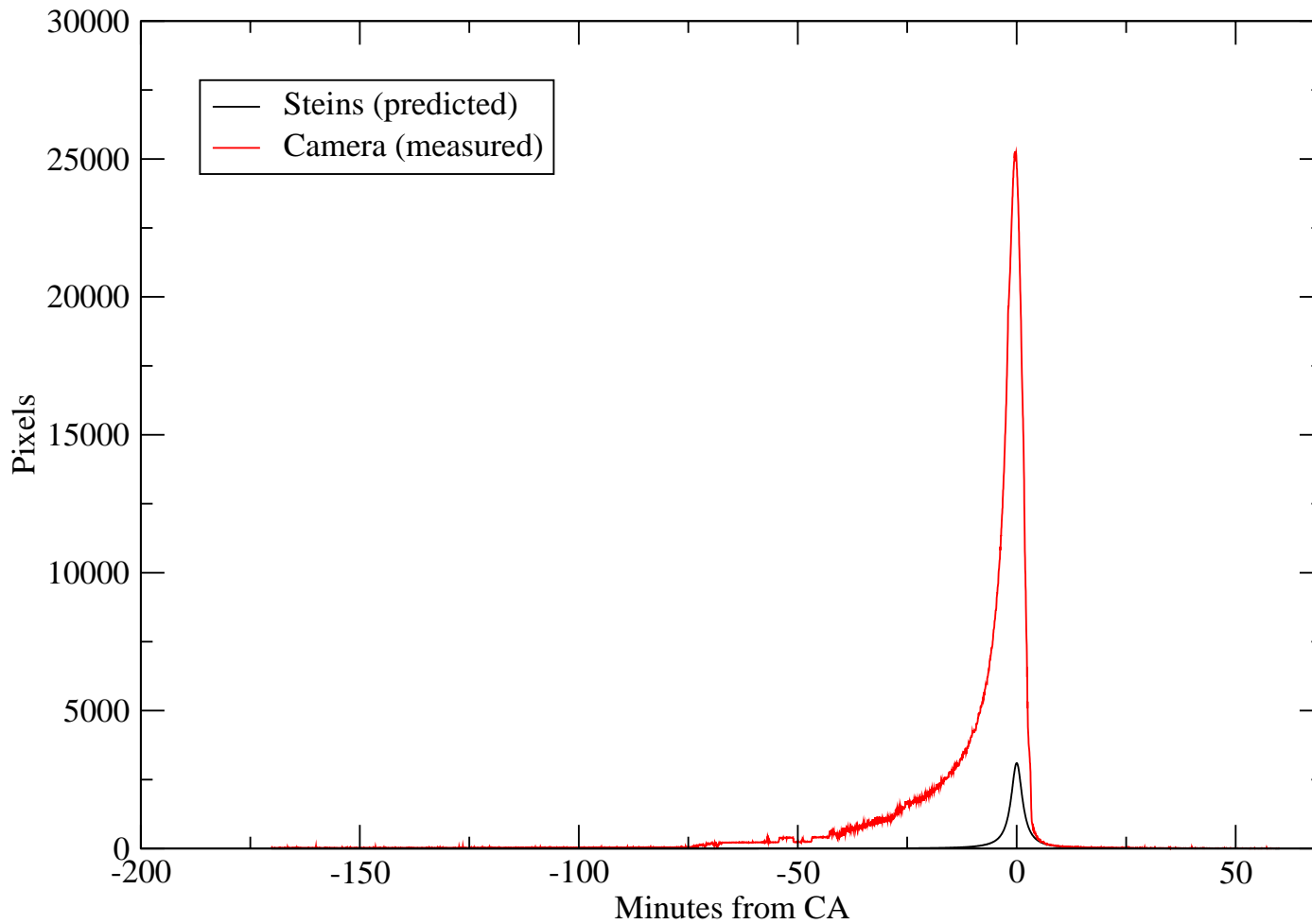

g

tion

d
 ir:
 imes
 osure
 size
 by factor
 1.55

behaviour:
 nes more
 :ected
 d/or full
 ected.
 ig”

Missions

Navigation Camera Tracking Performance (3)

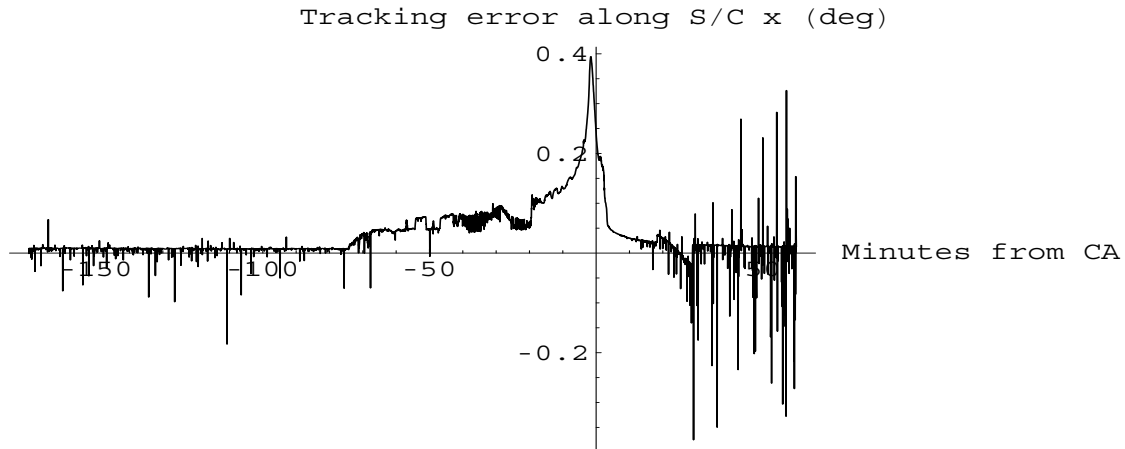

CCD blooming into full/half rows =>

Camera tracking disturbed along rows (i.e. S/C x-axis or tracking angle)

Max error 0.4 deg

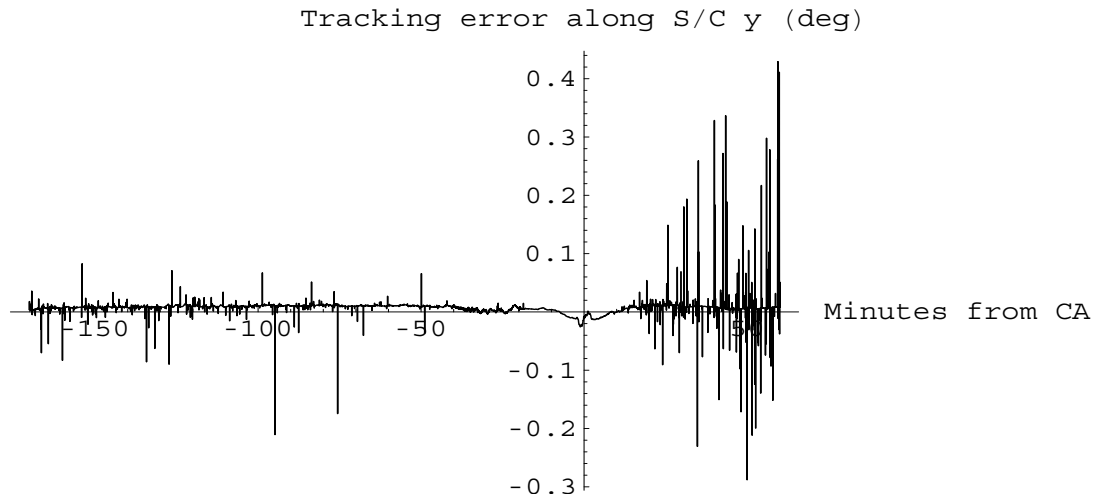

Camera tracking ok along columns (i.e. S/C y-axis or out-of-plane angle)

Max error ~0.01 deg

S/C Pointing Performance (1)

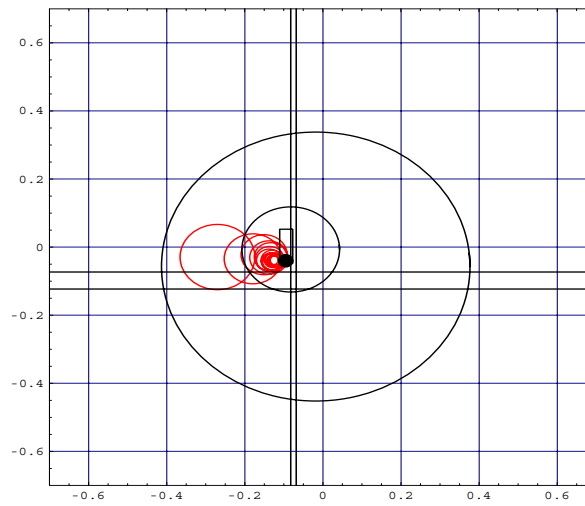
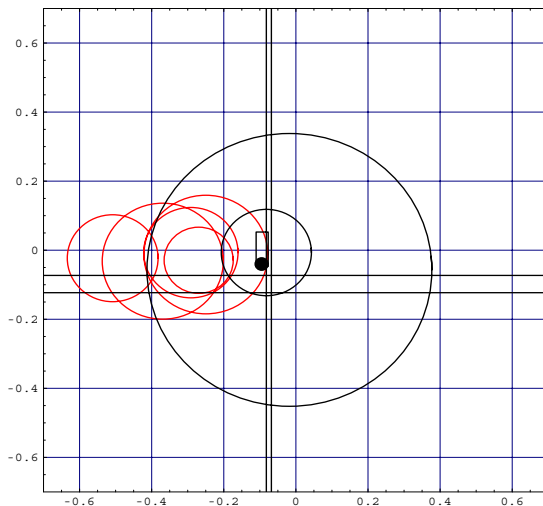
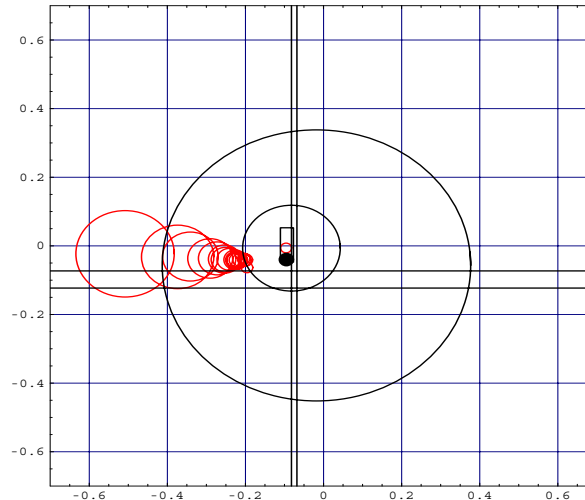
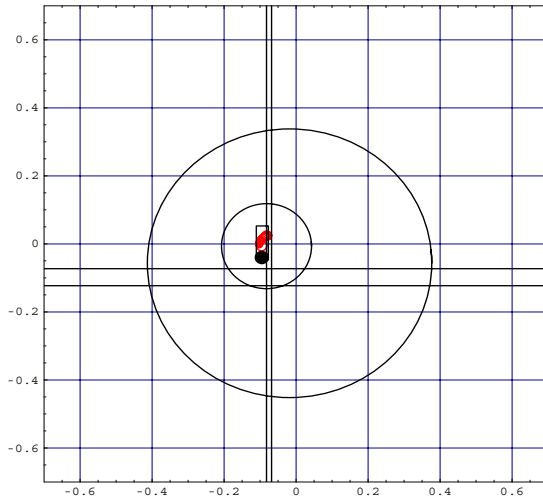

Steins (red circles)
w.r.t payload

top left:
AFM Entry – 10 min.
-> AFM Entry

top right:
AFM Entry
-> AFM Entry + 18 min.

bottom left:
AFM Entry + 18 min.
-> AFM Entry + 22 min.

bottom right:
AFM Entry + 22 min.
-> AFM Entry + 40 min.

S/C Pointing Performance (2)

Asteroid autonomous tracking was successful, i.e. pointing considerably better than with open loop pointing. But the nominal performance was not achieved:

- Navigation Camera performance before flyby was not nominal:
Steins was not tracked due to presence of warm pixels
Non-nominal configuration was used, which also showed misperformance:
up to 0.4 deg measurement error along S/C x-axis due to blooming
- S/C pointing requirement: < 0.3 deg
allocation for AOCMS < 0.15 deg
AOCMS allocation was not met for ca. 9 minutes
Maximum error was ca. 0.4 deg, along S/C x-axis
Pointing along S/C y-axis was accurate
- Required settings for Lutetia flyby are still being analysed
Camera tracking tests with similar conditions shall be performed

Acknowledgements

FD Interplanetary Mission Support Section:

FD Manager: J. Fertig
Orbit Determination: T. Morley, F. Budnik
Manoeuvre Optimisation: V. Companys
Command Generation: M. Mueller

Attitude Monitoring / Image Processing:

U. Herfort (EDS)
D. Hocken (SSL)
S. Kielbassa (EDS)

Steins

Osiris/WAC image at 18:38:18 UTC



Steins distance: 803 km

Earth distance: 360,448,350 km