



Modeling the Risk of Fire/Explosion due to Oxidizer/Fuel Leaks in the Ares I Interstage



*Christy Hales
Rob Ring
Jim Stott S&MA QD33
NASA/MSFC
October 23, 2008*



- ◆ **Explain the process used to produce a model for estimation of risk of fire/explosion in the Ares I interstage**

- ◆ **Provide example outputs from the model**

- ◆ There are numerous potential leak sources of hydrogen and oxygen in the Ares I Interstage
- ◆ There are several ignition sources with sufficient energy to start a fire in the Interstage
- ◆ The volume is closed and vented
- ◆ Fire in the Interstage may result in loss of mission

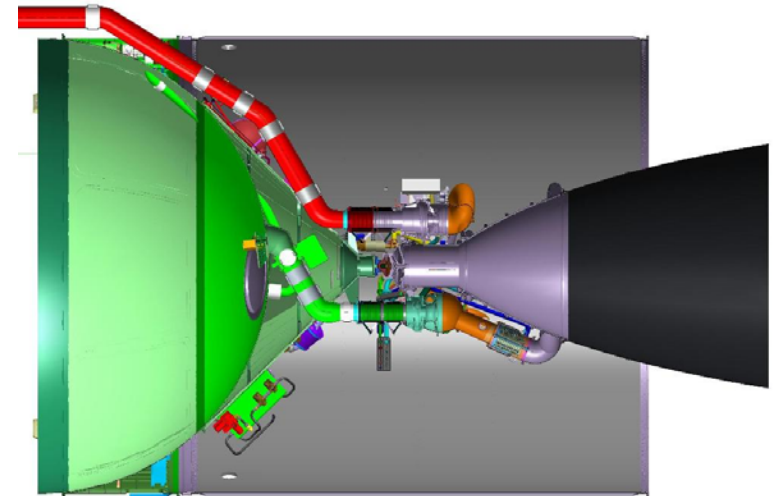
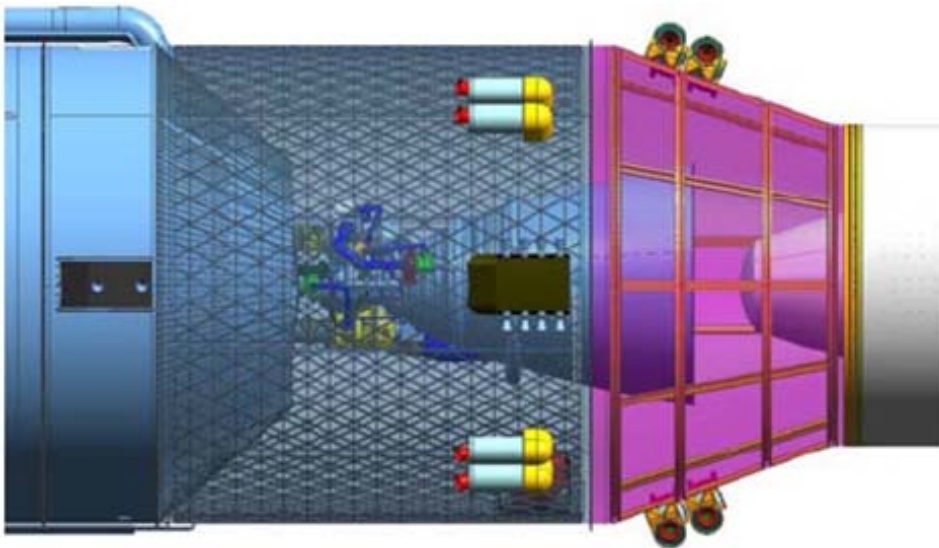

Ares I Launch Vehicle ISS trajectory

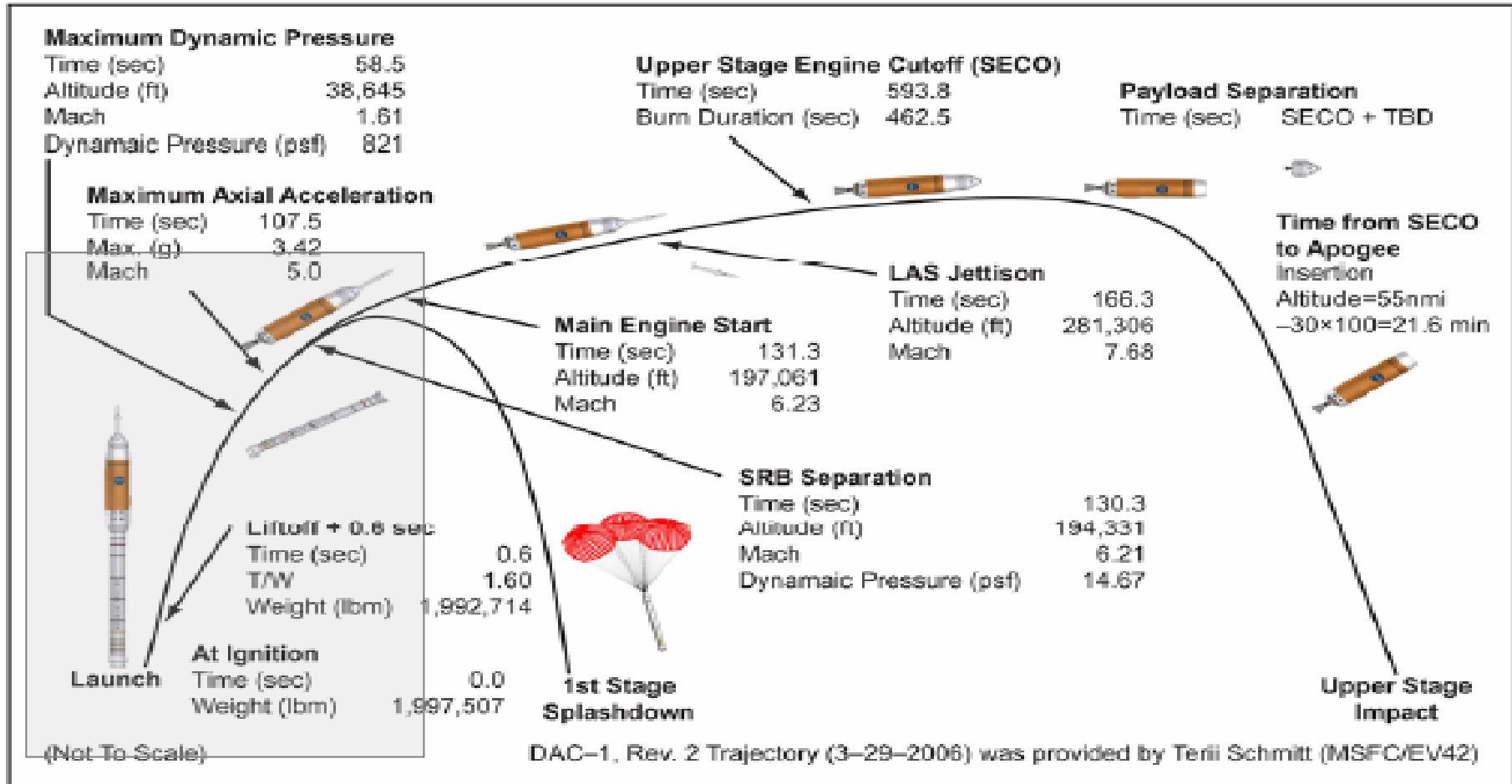



- ◆ **Developed for Upper Stage Probabilistic Risk Assessment (PRA) which supports the design and development of the Ares I Upper Stage**
- ◆ **This model improves upon previous NASA models**
- ◆ **This model quantifies the probability of deflagration assessed over the full mission profile using the Crystal Ball™ program for Monte Carlo analysis**

Trajectory Model

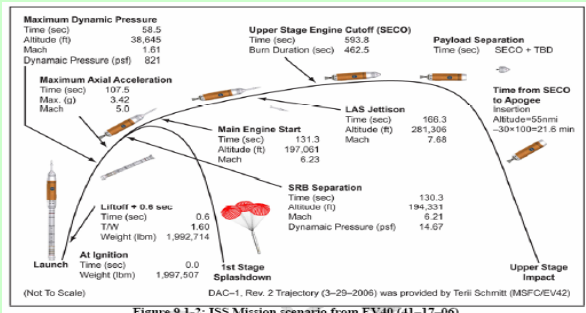
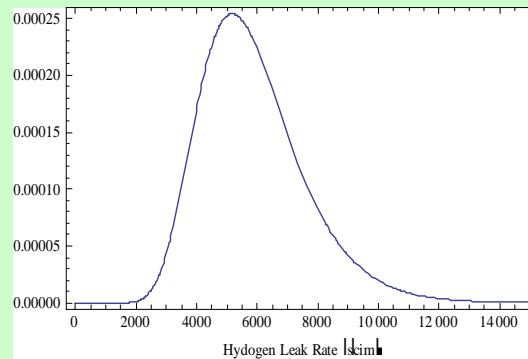
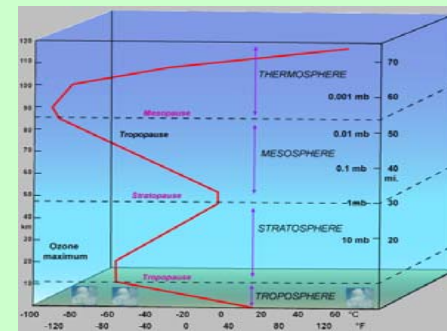

Figure 9.1.2: ISS Mission scenario from EV40 (41-17-06).

O2 & H2 Leak Models



Atmospheric Model



Environment Model

V = 5100 scf
Ideal Gas law (PV=nRT)
 $\Delta\% \propto n(i)$

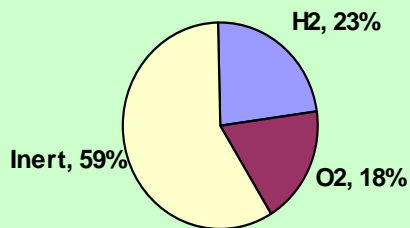

Flammability limits

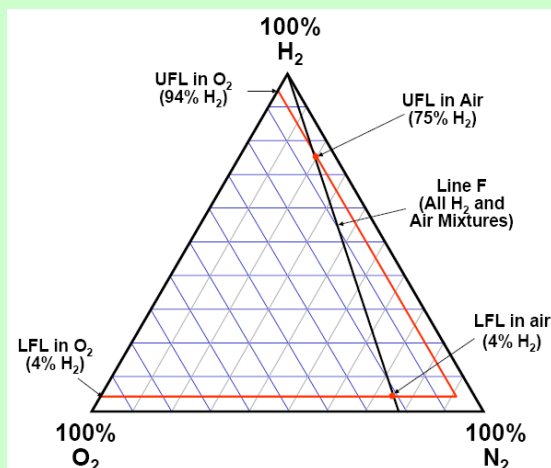

Post Processor

50,000 Monte Carlo samples

For each ascent altitude:

1. Fit Lognormal pdfs to H₂% and O₂% conc.
2. Calculate the probability of deflagration based on flammability constraints
3. Use the greatest mission probability



- ◆ **Pre-launch N2 purge is terminated at liftoff**
- ◆ **Initial fluid concentrations at T-0 from Purge and Hazardous Gas Integrated Product Team**
- ◆ **Leak rates of H2 and O2 are assumed to begin at T-0, then remain constant throughout ascent phase**
- ◆ **Deflagration occurs with certainty whenever all of the following conditions in the Interstage are met:**
 - **$LFL\% \leq H2\% \leq UFL\%$**
 - **$O2\% \geq LOI\%$**
 - **Pressure > 0.009 psia**
- ◆ **All nitrogen leaves the interstage before hydrogen and oxygen**
- ◆ **Internal and external pressure are equalized after each time step**



- ◆ **50,000 replications are performed in Monte Carlo analysis**
- ◆ **At each time step, the composition of the interstage is based on ideal gas law**
- ◆ **Distributions are fit to the hydrogen and oxygen concentration profiles for each time**
- ◆ **Distributions are fit to the LFL, UFL, and LOI at each time**
- ◆ **The hydrogen and oxygen distributions are compared to the distributions for LFL, UFL, and LOI for each time step to determine overlap**
- ◆ **Probabilities of fire/explosion are calculated for each time step**

- ◆ Data for Ascent profile comes from Atmosphere model for Eastern Test Range.
- ◆ Sampled Temp correlated to ground launch conditions and Pressure correlated to Temp
- ◆ Altitude and Time are correlated normal distributions
- ◆ Temperature and Pressure are normal distributions correlated with Altitude

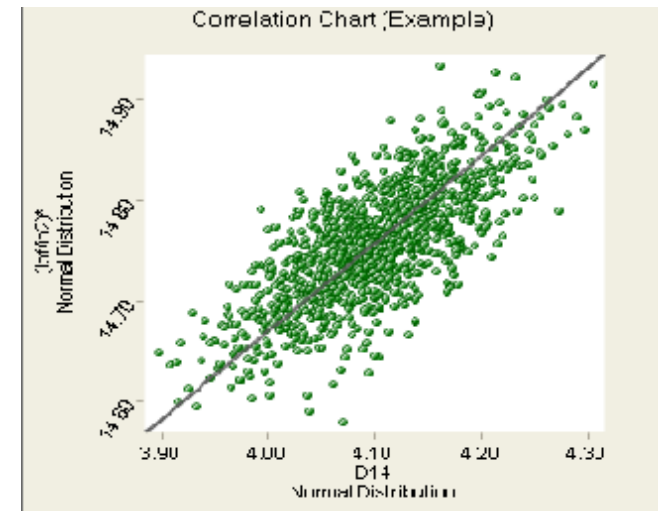
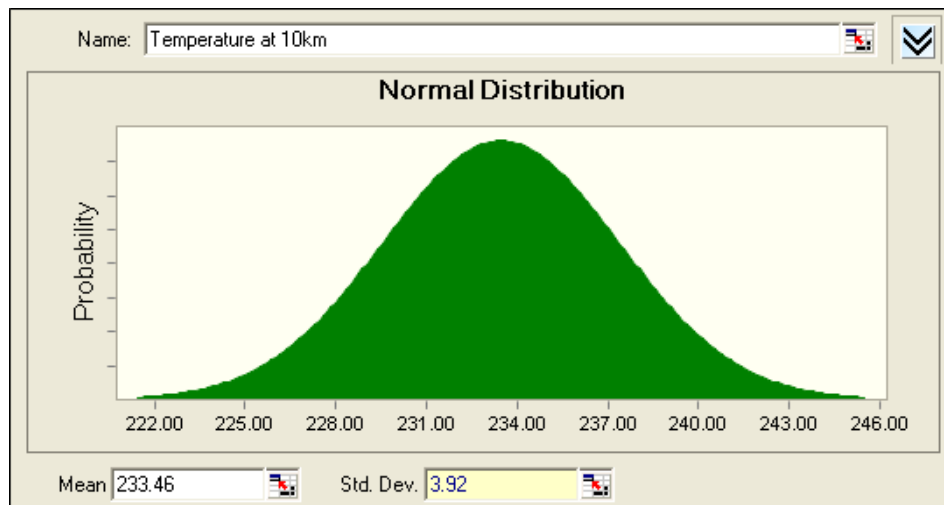

- ◆ UFL and LFL are functions of pressure and gas ratios
- ◆ LOI is approximately equal to LFL for hydrogen

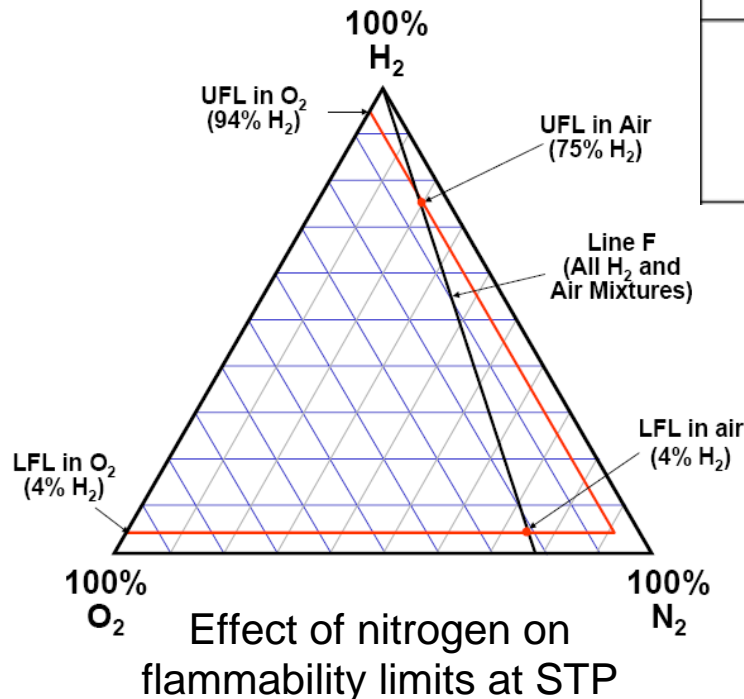

Conditions	Hydrogen Content vol%			
	Upper propagation		Downward propagation	
Hydrogen in air at reduced pressure with a 45 mJ (47.5 Btu) ignition source:				
Pressure kPa	25 cm Tube		2 L Sphere	
	Lower limit	Upper limit	Lower limit	Upper limit
20	≈ 4	≈ 56	≈ 5	≈ 52
10	≈ 10	≈ 42	≈ 11	≈ 35
7	≈ 15	≈ 33	≈ 16	≈ 27
6	20-30		20-25 (at 6.5 kPa)	

Effect of reduced pressure on flammability limit

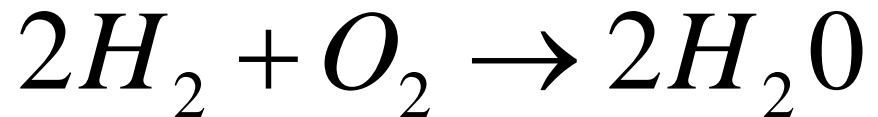

$$LOI \cong z \cdot LFL$$

Sample Output

O2 and H2 Concentration with Limits

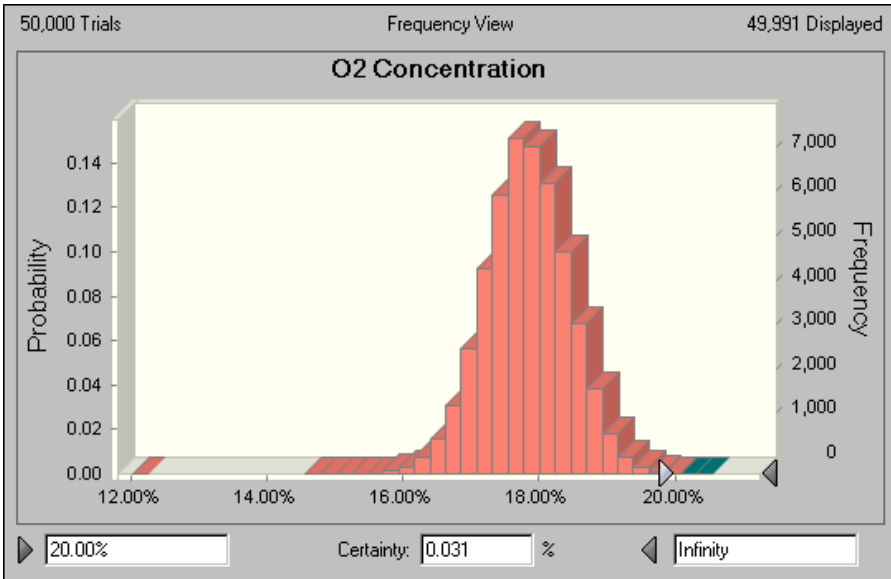
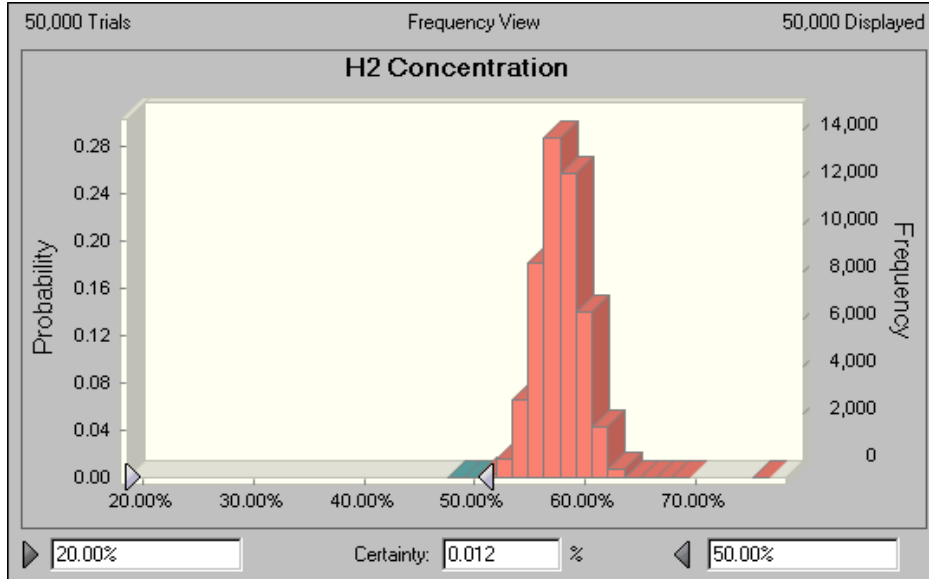
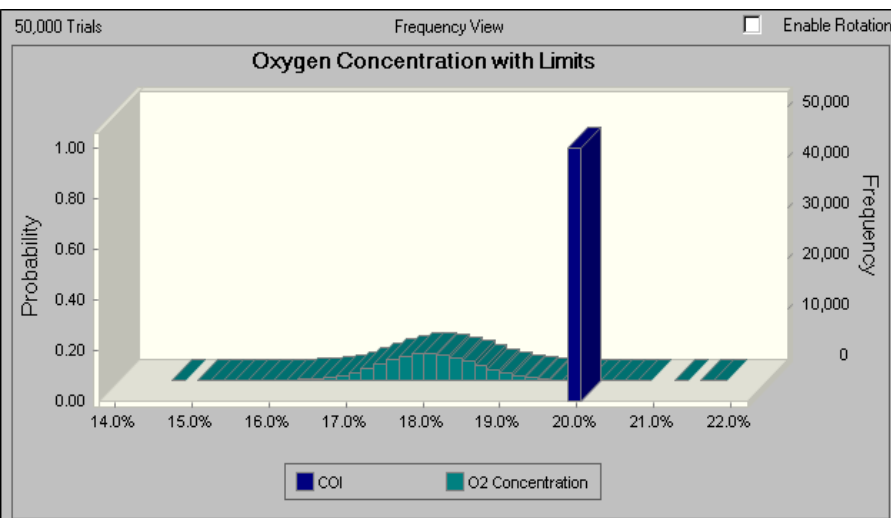
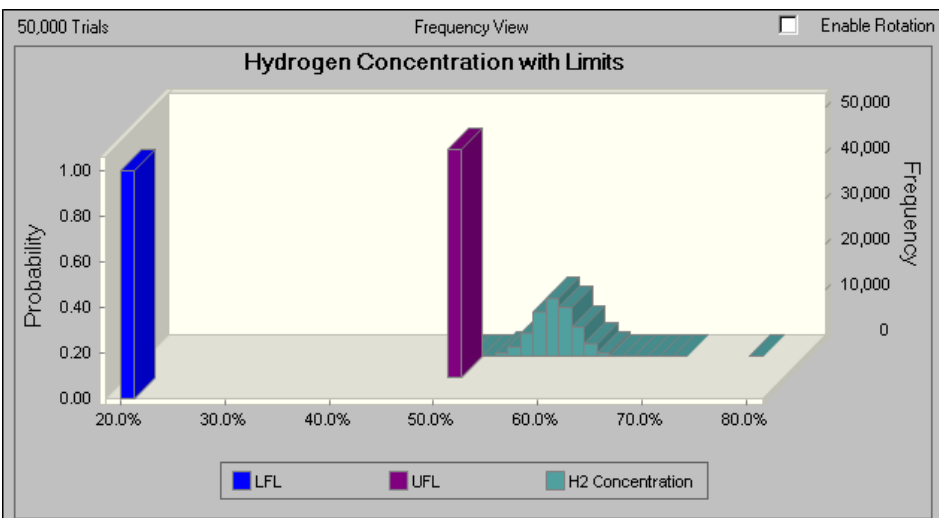



Log of Probability of Deflagration

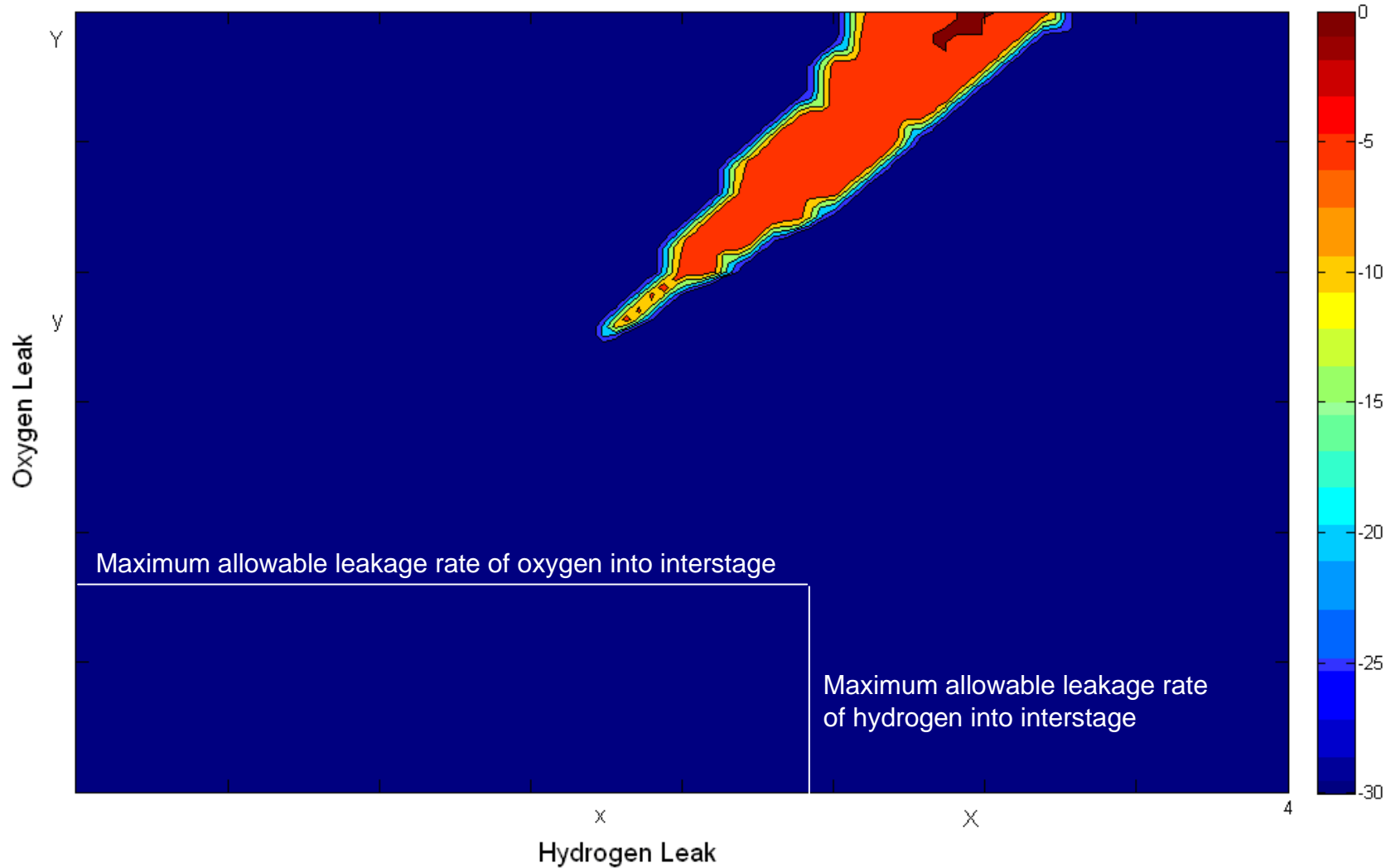



- ◆ **Instead of nitrogen leaving volume first, perfect instantaneous mixing and various combinations of the two were compared. The current model is very conservative**
- ◆ **Air incursion rates of up to 35,000 scim were examined. Since the LOI is above 21% by the time fire is most likely to occur, air incursion is not seen as a substantial contributor to fire at this time**
- ◆ **The pressure lag associated with several venting scenarios being considered using worst case trajectories was found to decrease the risk of fire since nitrogen left the interstage more slowly (no Monte Carlo Analysis able to be performed in these cases)**
- ◆ **Various situations with additional leaks beyond nominal were examined and typically required several leaks to raise the probability above that for nominal rates**
- ◆ **The accuracy of the Ideal Gas Law ($PV=nRT$) was compared with the Van der Waal's equation of state. The error introduced by using the Ideal Gas Law is $<0.1\%$**



- ◆ **The model has been used to help determine leakage allowables within the Interstage**

- ◆ **Forward work:**
 - **Study the impact of key assumptions, such as fluid mixing**
 - **Quantify the risk of specific leak scenarios**
 - **Estimate the increase in risk associated with dependent multiple leaks**

Questions?

Backup



- ◆ **Trajectory Model**: CLV GN&C System Design Document (CxP 72069). Worst case trajectories were provided by Will Downs (EV33)
- ◆ **Atmosphere Model**: Annual mean temperature and pressure versus altitude for the Eastern Test Range. Constellation Program Natural Environment Definition for Design (NEDD) (CxP 70044)
- ◆ **Flammability Limits**: ANSI/AIAA G-095-2004 American National Standard Guide to Safety of Hydrogen and Hydrogen Systems
- ◆ **Environment Model**: Internal pressure differential versus altitude pressure data were provided by Will Downs. Initial Interstage gas concentrations at T-0 and He purge rates during ascent were provided by Bruce Frankenfield (GRC, P&HG)



Is

[R.J2ERD.3.4.026] J-2X Propellant Leakage

The J-2X shall limit the leakage of propellants into the interstage to less than the following when propellants are present in the engine prior to engine start.

Propellant	Leakage	Conditions
Hydrogen	19,500 scim [TBR-3.4.026-1]	up to 50 psia @ LH2 inlet
Oxygen	6,700 scim [TBR-3.4.026-2]	up to 95 psia @ LO2 inlet

Rationale: The table presents the maximum propellant leakage prior to engine start. These values are necessary to maintain safe conditions in the interstage. Trace [R.J2X.89]

Was

[R.J2ERD.3.4.026] J-2X Propellant Leakage

The J-2X shall limit the leakage of propellants into the interstage to less than the following when propellants are present in the engine prior to engine start.

Propellant	Leakage	Conditions
Hydrogen	19,500 scim [TBR-3.4.026-1]	up to 50 psia @ LH2 inlet
Oxygen	5,000 scim [TBR-3.4.026-2]	up to 95 psia @ LO2 inlet

Rationale: The table presents the maximum propellant leakage prior to engine start. These values are necessary to maintain safe conditions in the interstage. Trace [R.J2X.89]



- ◆ **Maximum leakage exceeding allowable flow requirements considered low risk**
 - RSS method more realistic – maximum leakage is absolute maximum worst case for all seals
 - RSS method matches closely with a Monte Carlo simulation of maximum seal leakages (current drain configuration)
 - RSS = 13871 scim
 - Monte Carlo Simulation 3σ maximum = 13427 scim
 - Limits for hydrogen concentration in interstage are 1% for first 70 seconds of flight, then increasing to 2.5% between 70 and 95. However, lower flammability limit for hydrogen is 4%
 - Proposed configuration max will exceed 1% at ~ 50 seconds and increases to 1.2% at 70 seconds



- ◆ **Current allowable oxygen leakage rate into interstage area is 5000 scim max**
- ◆ **Hazardous gas analysis shows this limit can be increased by 1700 scim or 6700 scim maximum**
- ◆ **Leakage flow from the shaft seals of the Gas Generator Oxidizer Valve (GOV) and Main Oxidizer Valve (MOV) expected to be 1200 scim maximum per valve**
 - Maximum total additional leakage – 2,400 scim
- ◆ **Current leakage expected (RSS) 2,602 scim, maximum 3516 scim**
- ◆ **Proposed leakage (RSS) 4904 scim, maximum 5916 scim**
- ◆ **Maximum and RSS leakage values meet updated maximum of 6700 scim**
 - ICD update required

Histogram for He scim

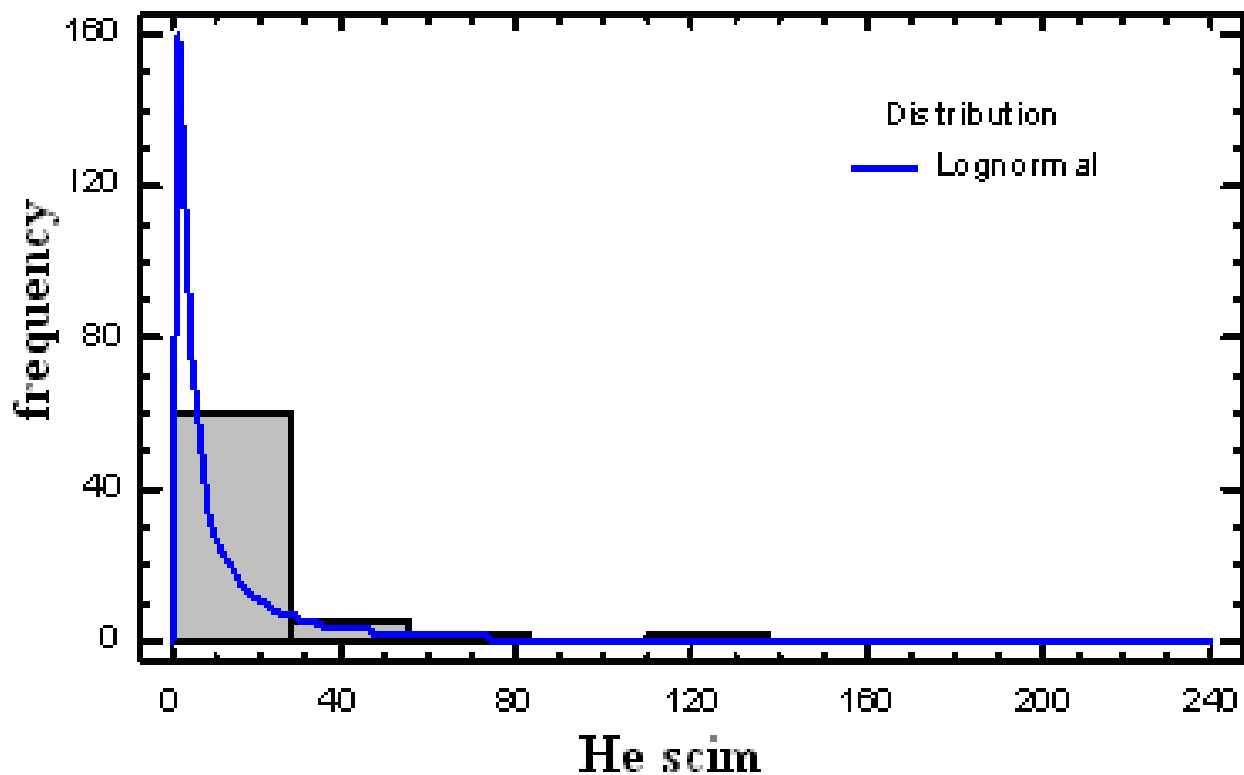

Histogram/lognormal fit: SSME
O1/F1 interface helium leak data