

# Modelling the SURF detector response in mixed electron/proton environments

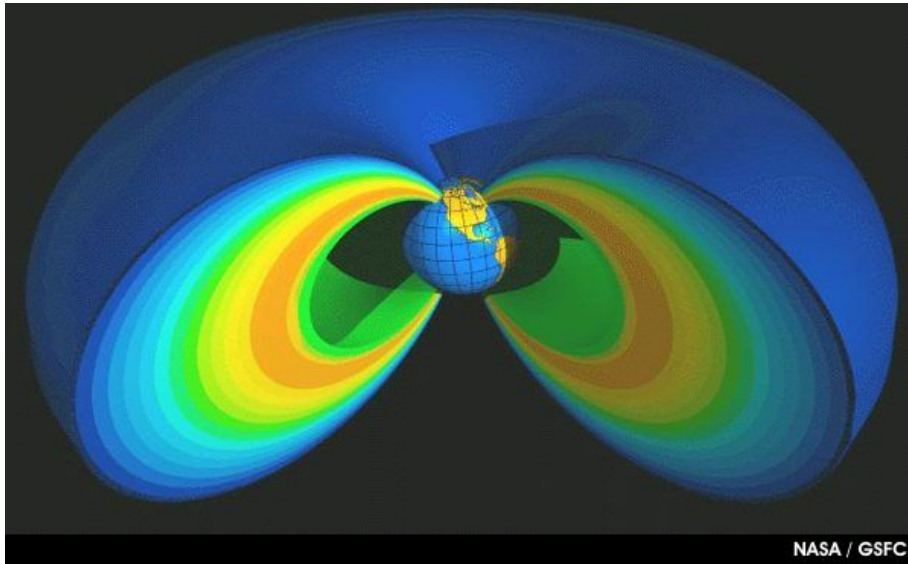

A Hands, K Ryden, C Dyer, P Morris, K Ford  
Ionising Radiation Detection & Data Exploitation Workshop

17<sup>th</sup> October 2007, ESTEC

QinetiQ

# Outline

- MEO radiation environment
- Internal charging
- SURF instrument
- Trapped electron spectrum
- Proton contributions to SURF
- GIOVE-A Merlin data

# Medium Earth Orbit

- Inbetween LEO and GEO
- Orbital periods range from few hours to ~1 day
- Suitable for global positioning (navigation) satellite constellations
- Radiation hazards:
  - Solar particle events
  - Galactic Cosmic Rays
  - Intense trapped radiation environment (electrons & protons)



# Van Allen Belts

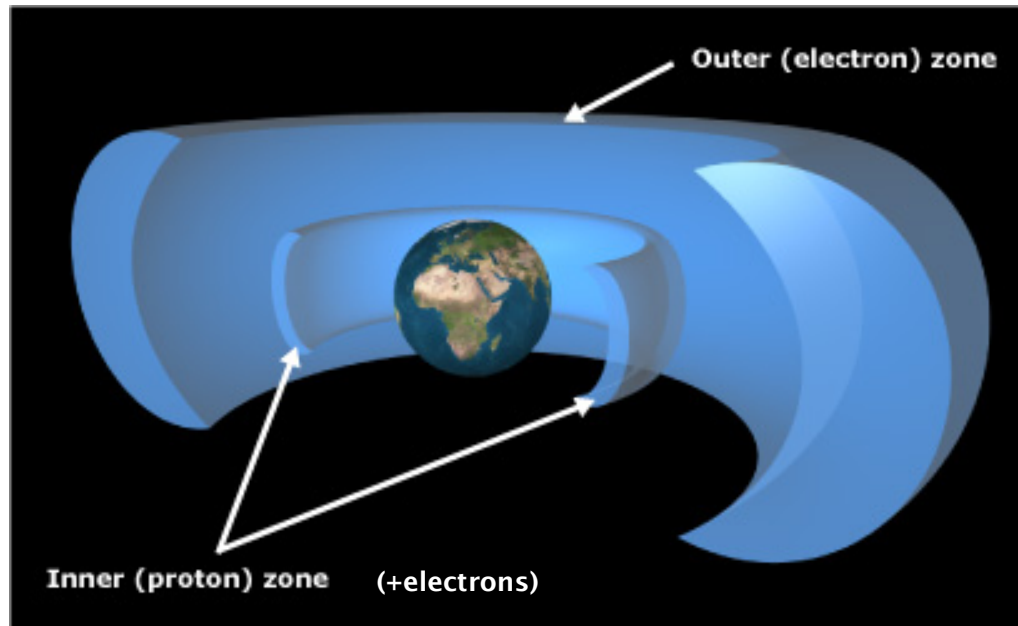

- High energy particles trapped in toroidal drift shells
- Inner & outer electron belts
- Single proton belt

17<sup>th</sup> October 2007, ESTEC

# AE8 and AP8 models

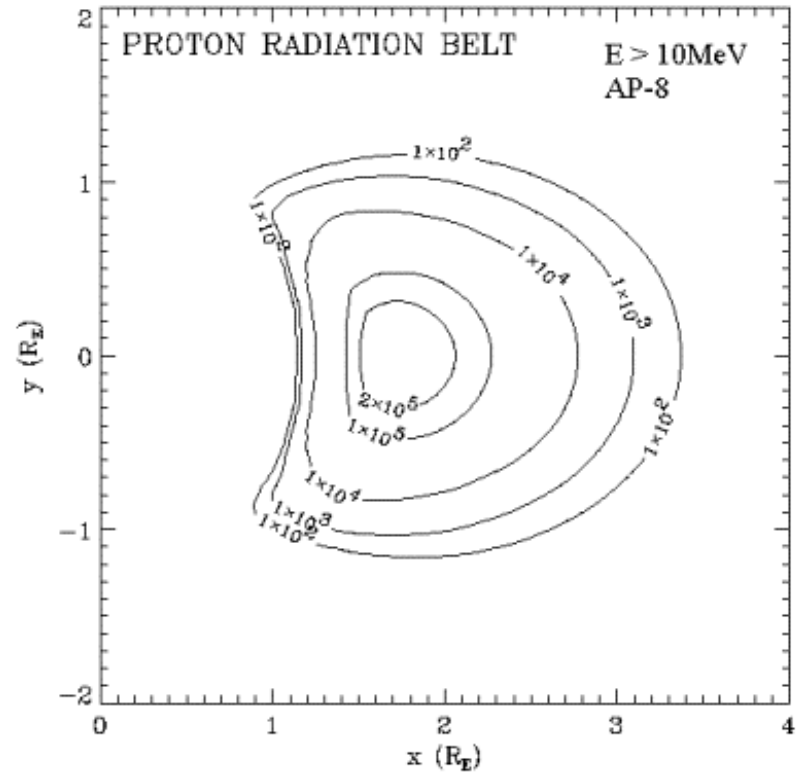
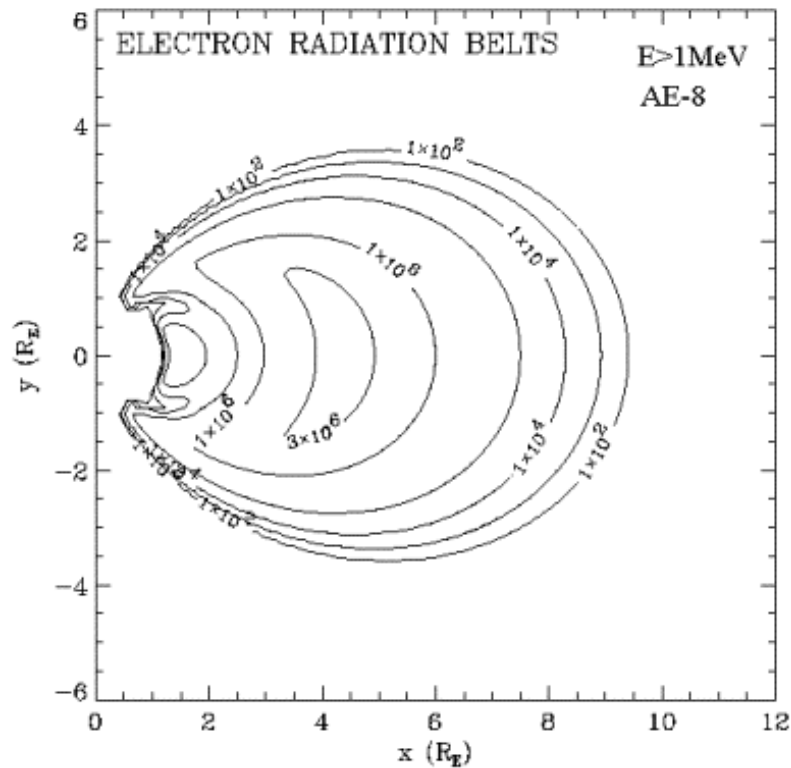

- High energy particles pose internal charging hazard

# Internal Charging

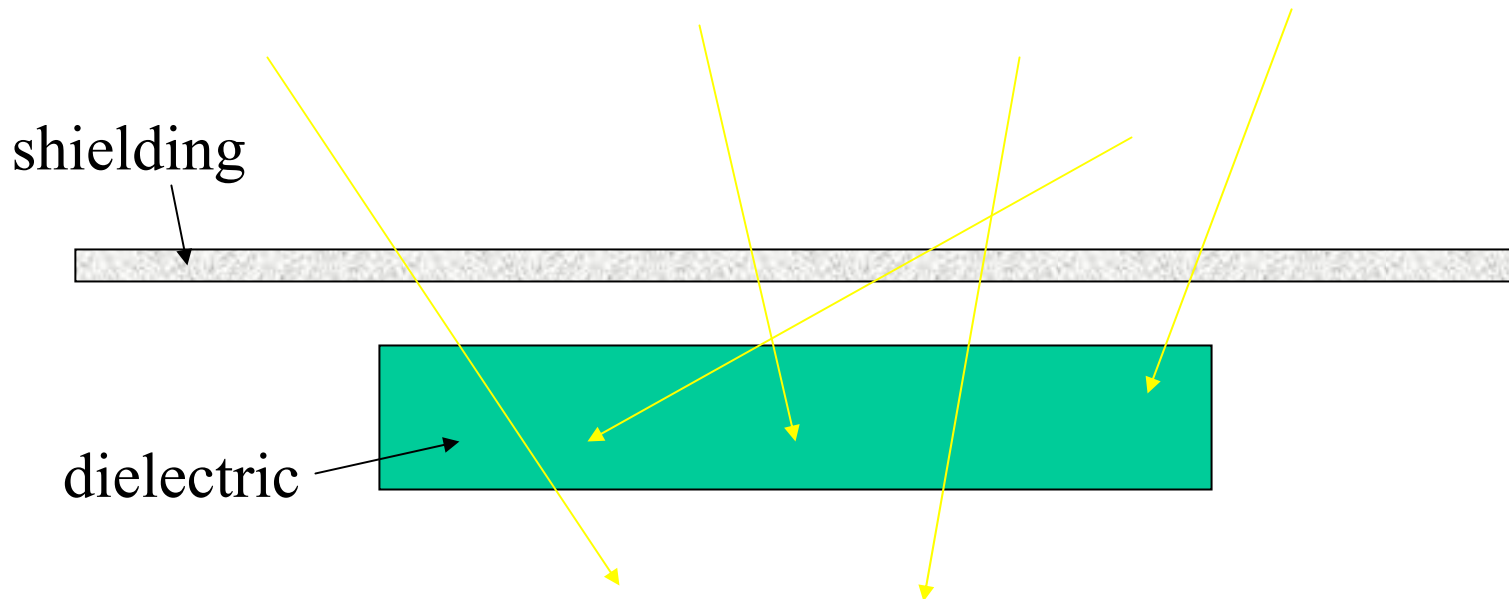

- Relativistic electrons penetrate spacecraft shielding
- Net charge builds up in dielectric material
- ESD events can cause anomalies and failures



# SURF (1<sup>st</sup> generation)

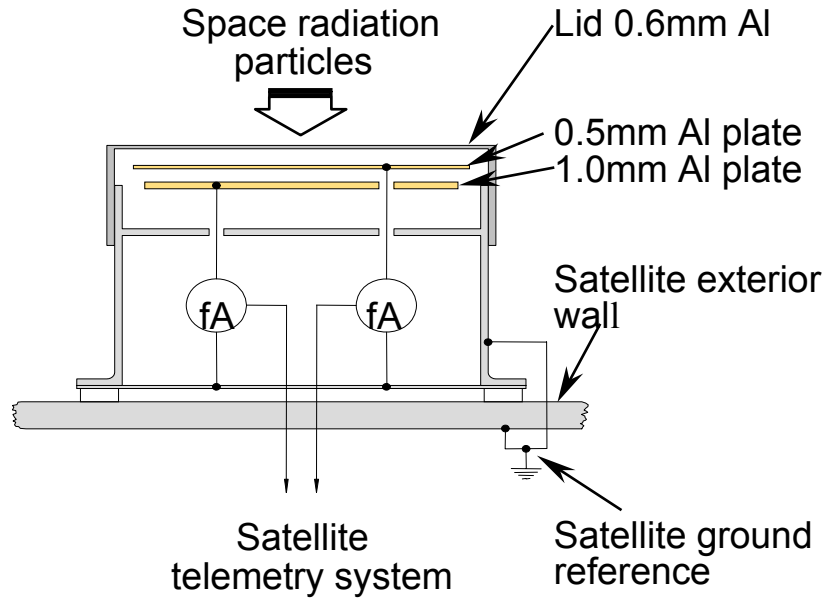
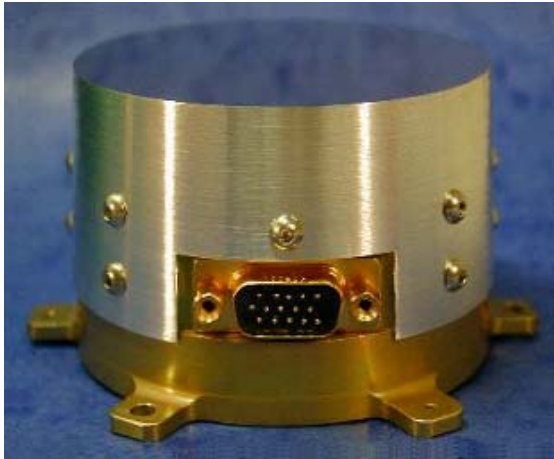

- Two charging plates
- Flown on STRV1d

# Example SURF results

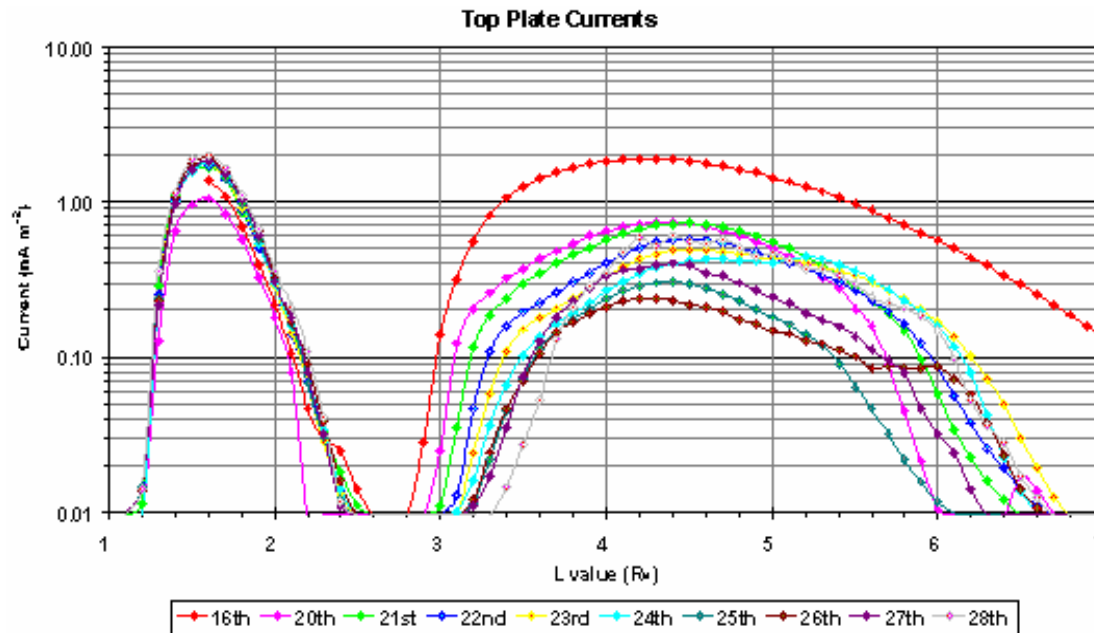

- GTO orbit → wide range of L shell measurements possible
- Clearly well suited to measuring electron intensities
- Limited hardness information

# QinetiQ's radiation monitors

## CREAM Cosmic Ray Effects and Activation Monitor (1986 onward)

- Charge deposition events in Si
- Flights: Shuttle(10 flights) /BA Concorde/Qantas/



## CREDO Cosmic Ray Effects and Dosimetry Experiment (1991 onward)

- Ion LET spectra and proton flux
- Flights: UoSAT, STRV1a, Skynet, APEX, MIR, MPTB



## Merlin (2005 onward)

- Charging/LET spectra/proton flux/TiD
- Flights: Giove-A, LWS/SET

## SURF (2000 onward)

- Surface charging and internal charging (electron flux)
- Flights: STRV1d



# SURF on Merlin

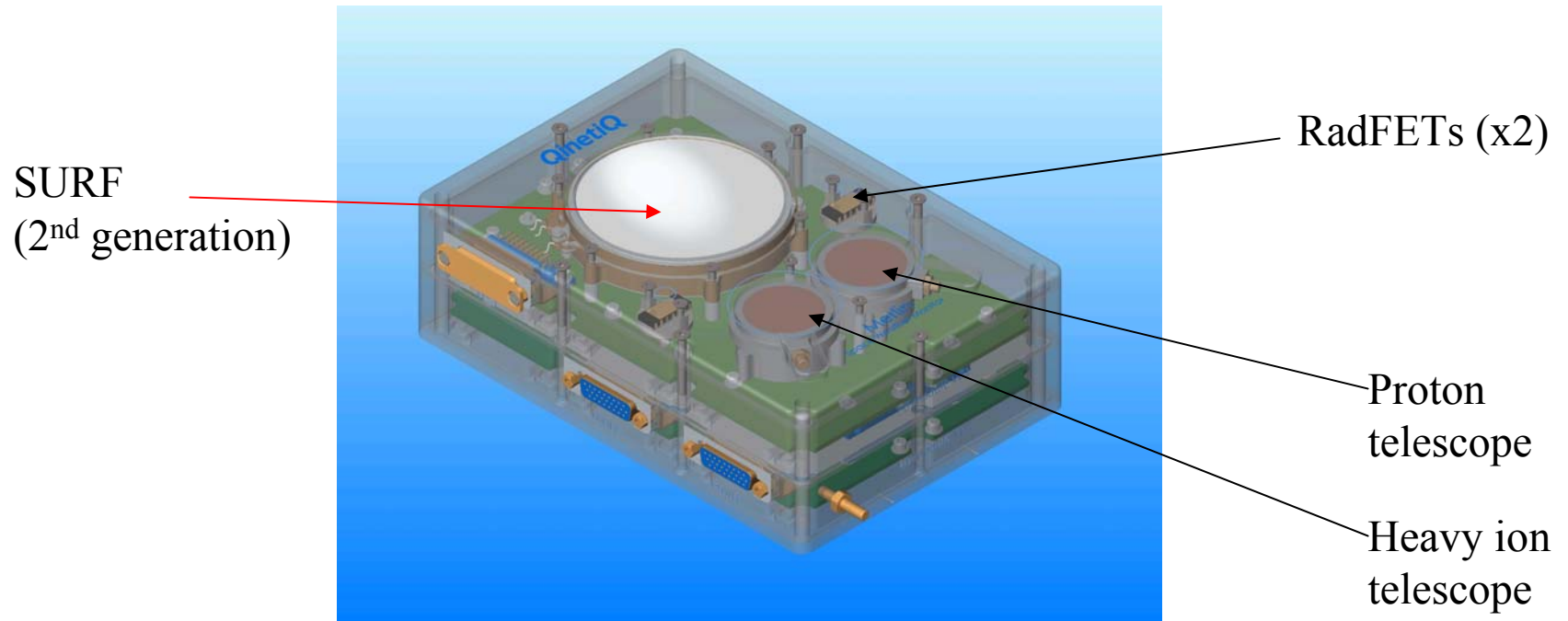

- Three charging plates (behind varying shielding depths)  
→ increased spectral information

# Current measuring plates

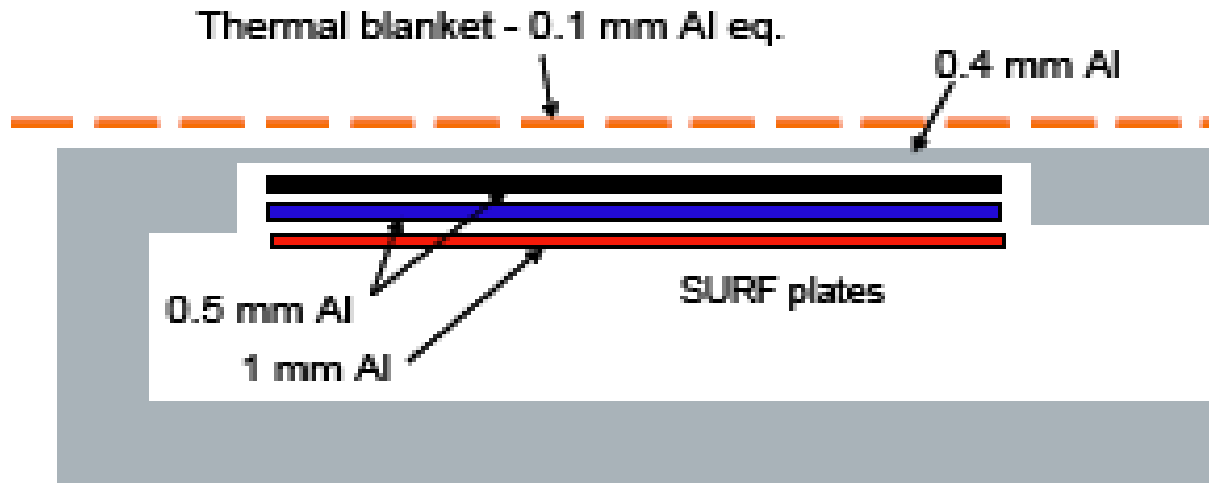

- Three plates to measure overlapping electron energy ranges
- Need to know electron response functions

# Plate response to electrons

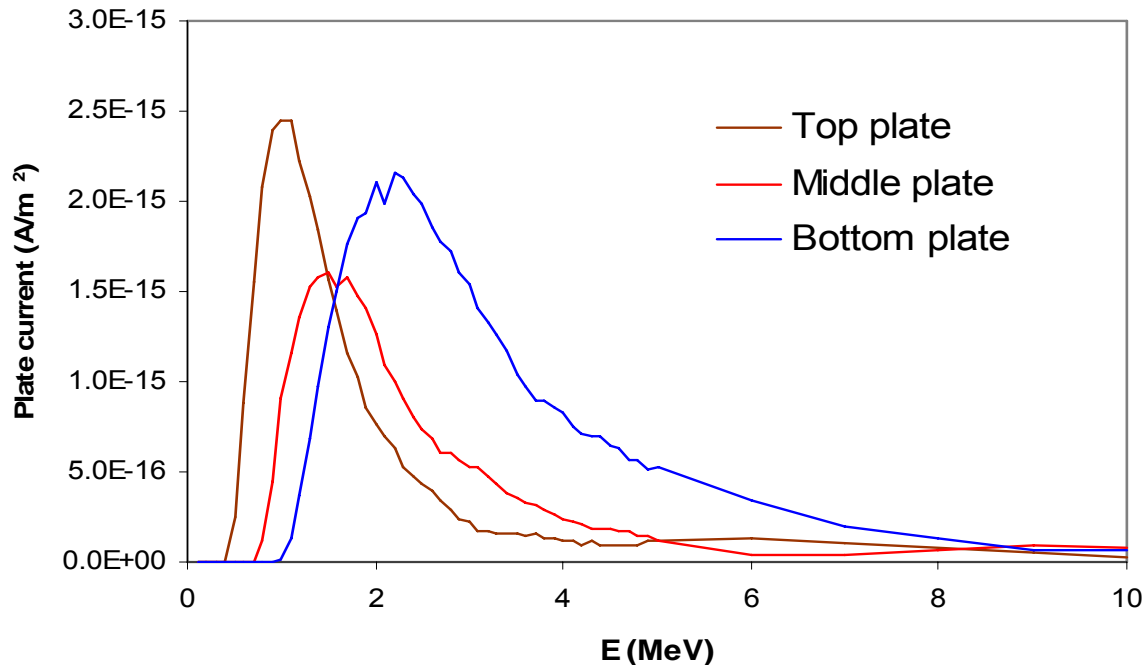

- Electrons from  $<1$  MeV to  $\sim 10$  MeV detected by SURF
- Lower plate has strong response due to increased thickness

# Spectral Information

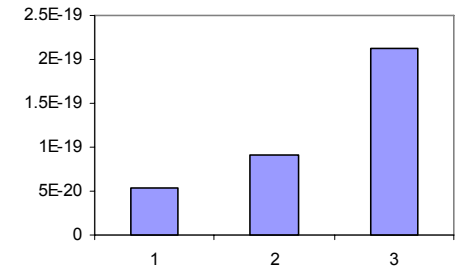
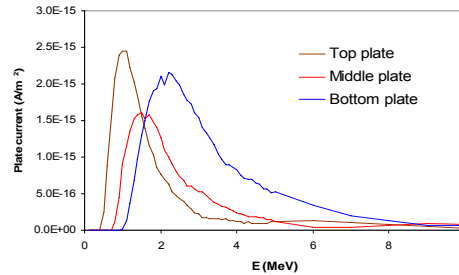
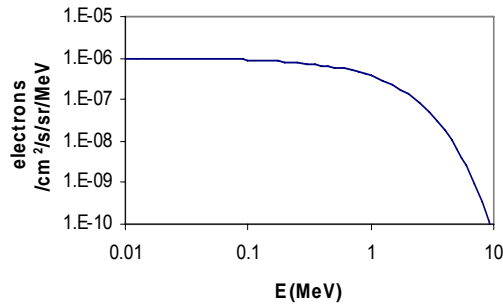

Electron  
spectrum

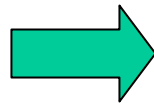

Response  
Functions

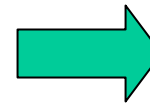
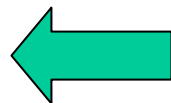

Plate  
Currents

Need reverse process!

Model  
Spectrum



Known  
Response

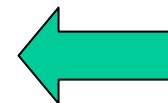

Measured  
Currents

# Plate current ratios

- Calculate predicted current ratios
- For example:  $f(E) = Ae^{-E/E_0}$

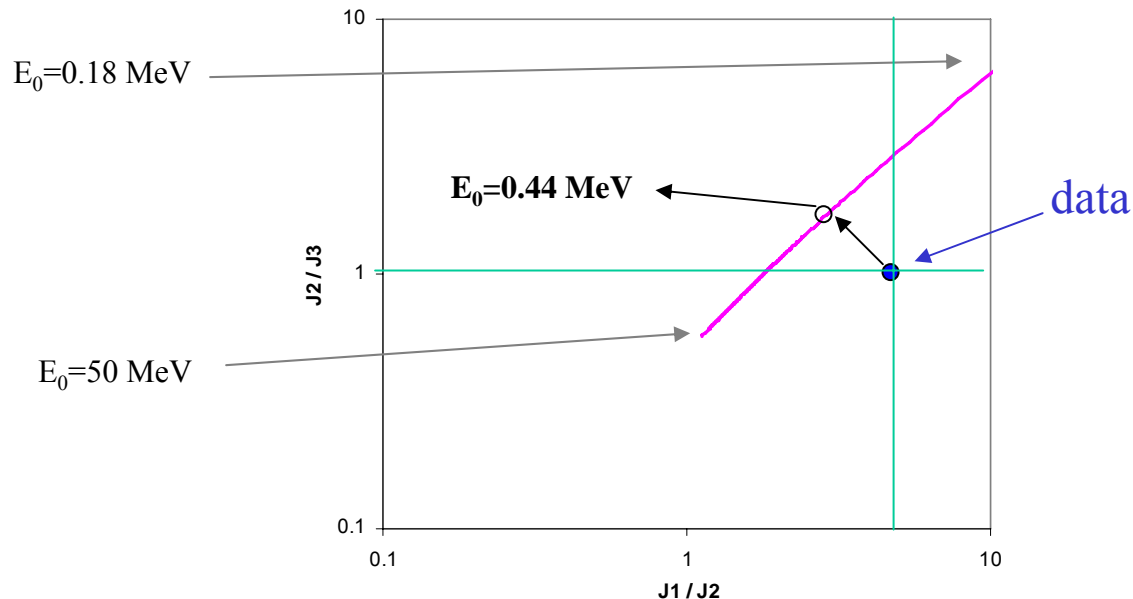

- Find  $E_0$  by minimising logarithmic difference between data and 'ideal' trend line

All very well and good but what  
about some actual data?

# Merlin on GIOVE-A

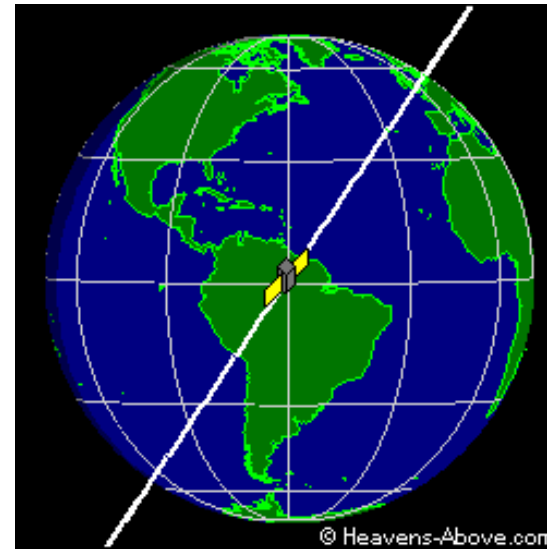
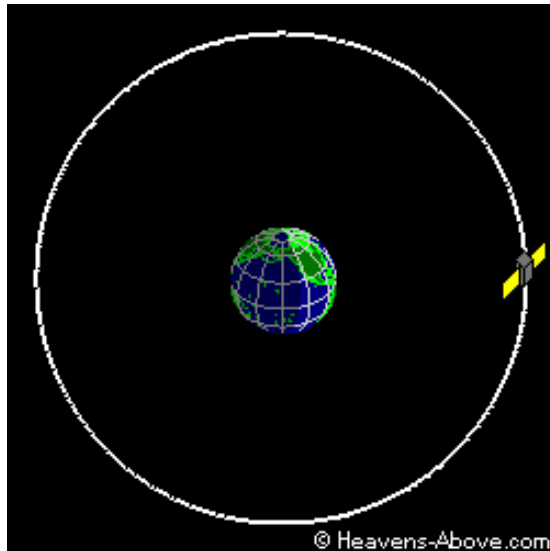

- Circular Orbit, altitude  $\sim 23,000$  km ( $L=4.7$  at equator)
- Inclination =  $56^\circ$

17<sup>th</sup> October 2007, ESTEC

# GIOVE-A c.f. Van Allen

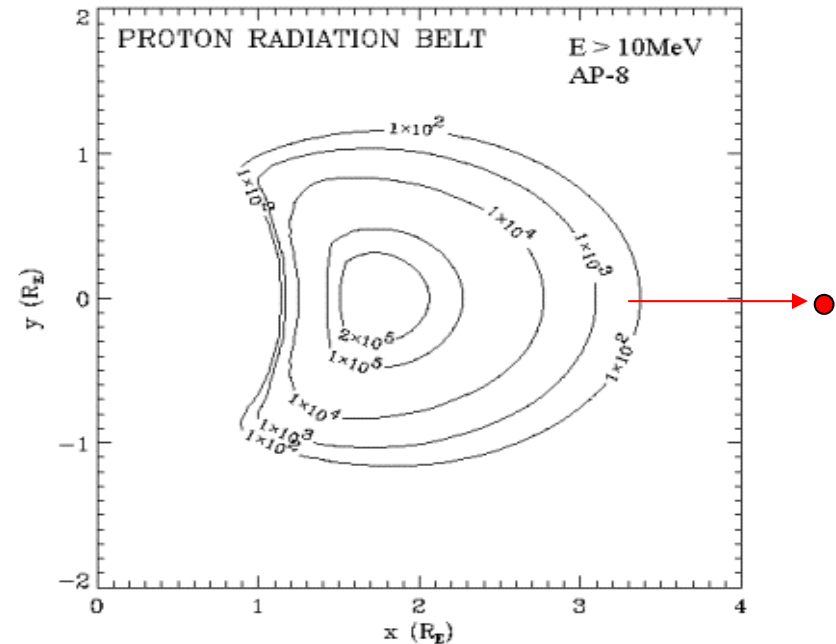
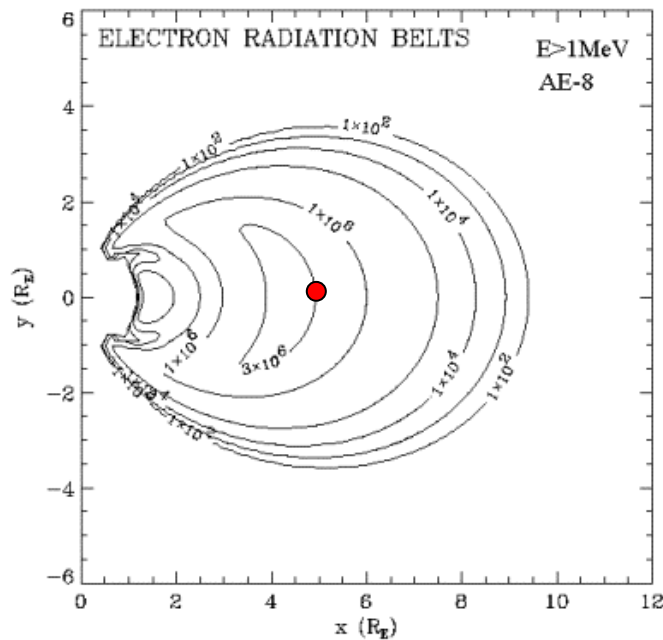

- Close to peak in outer electron belt (when crossing magnetic equator)
- ‘Outside’ proton belt

17<sup>th</sup> October 2007, ESTEC

# GIOVE-A c.f. Van Allen

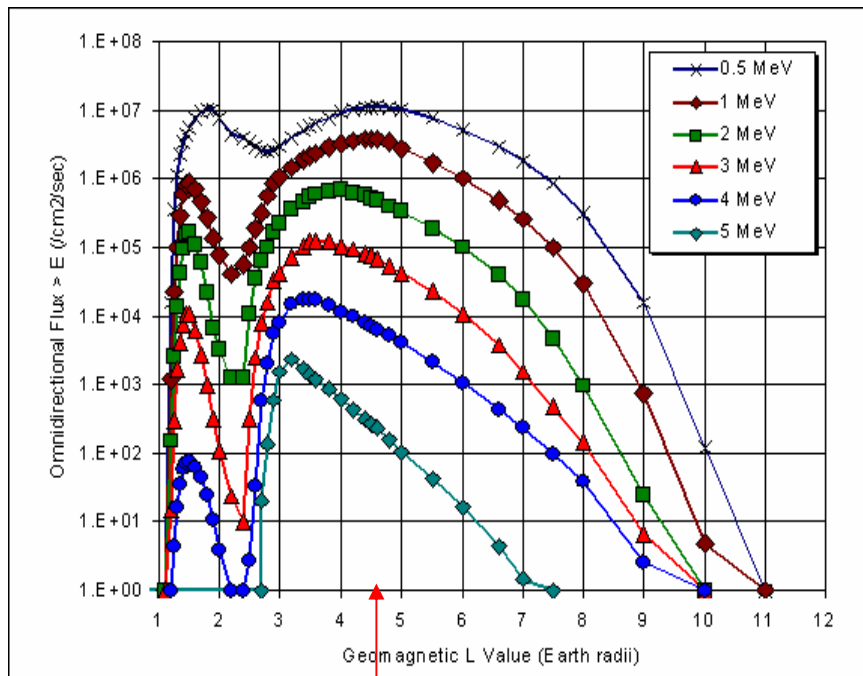

GIOVEA

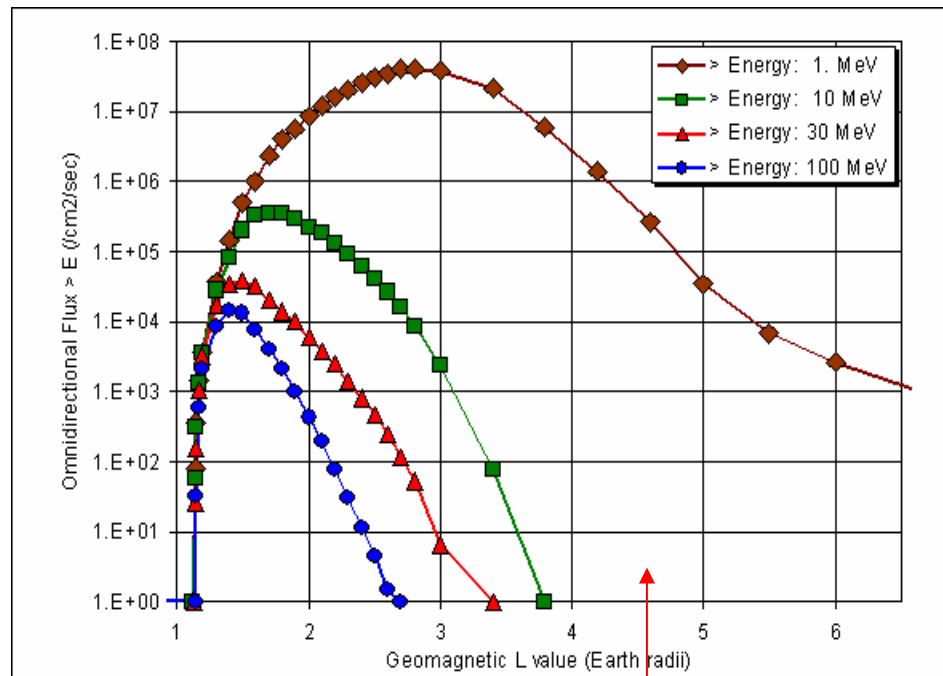

GIOVEA

(SURF insensitive to soft protons – more later)

# Prediction

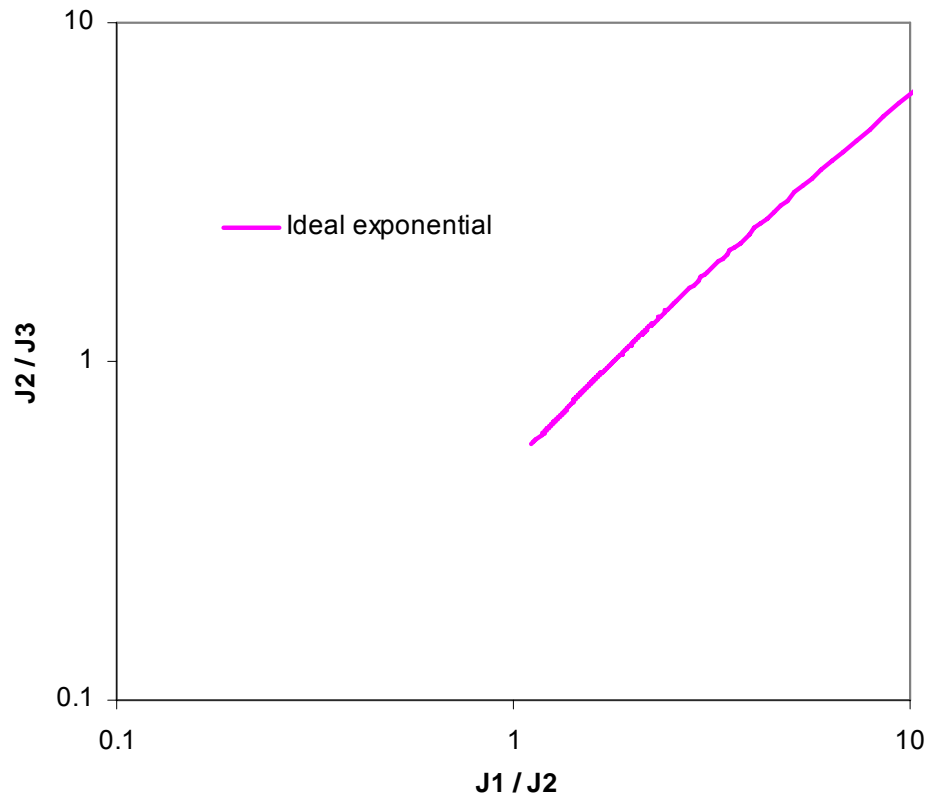

# Merlin SURF data

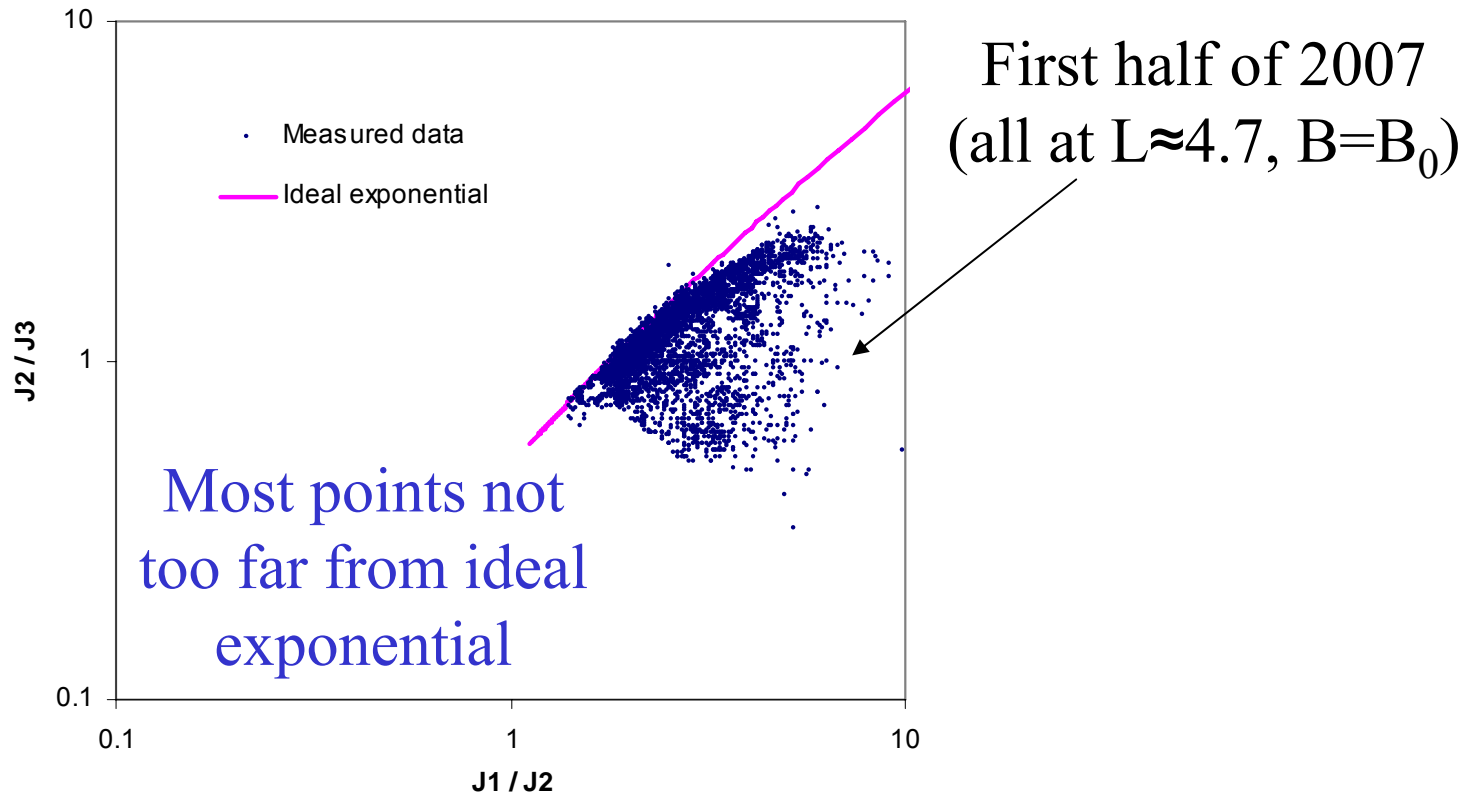

- $E_0$  found for each point  $\rightarrow$  flux information follows  
(alternative functions can be used)

17<sup>th</sup> October 2007, ESTEC

# Time series

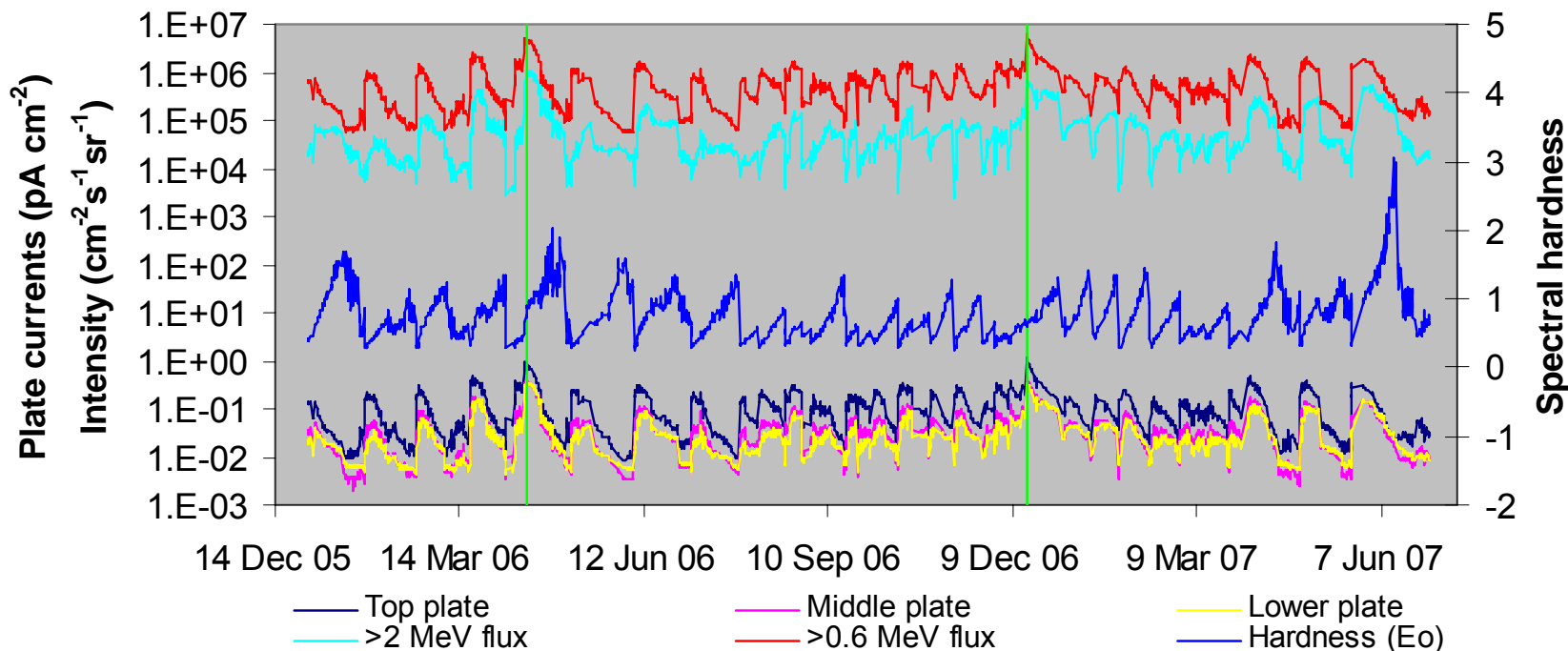

- Folding energy modulation follows intensity periodicity (dominant frequency is ~27 day synodic solar rotation)

# Time series

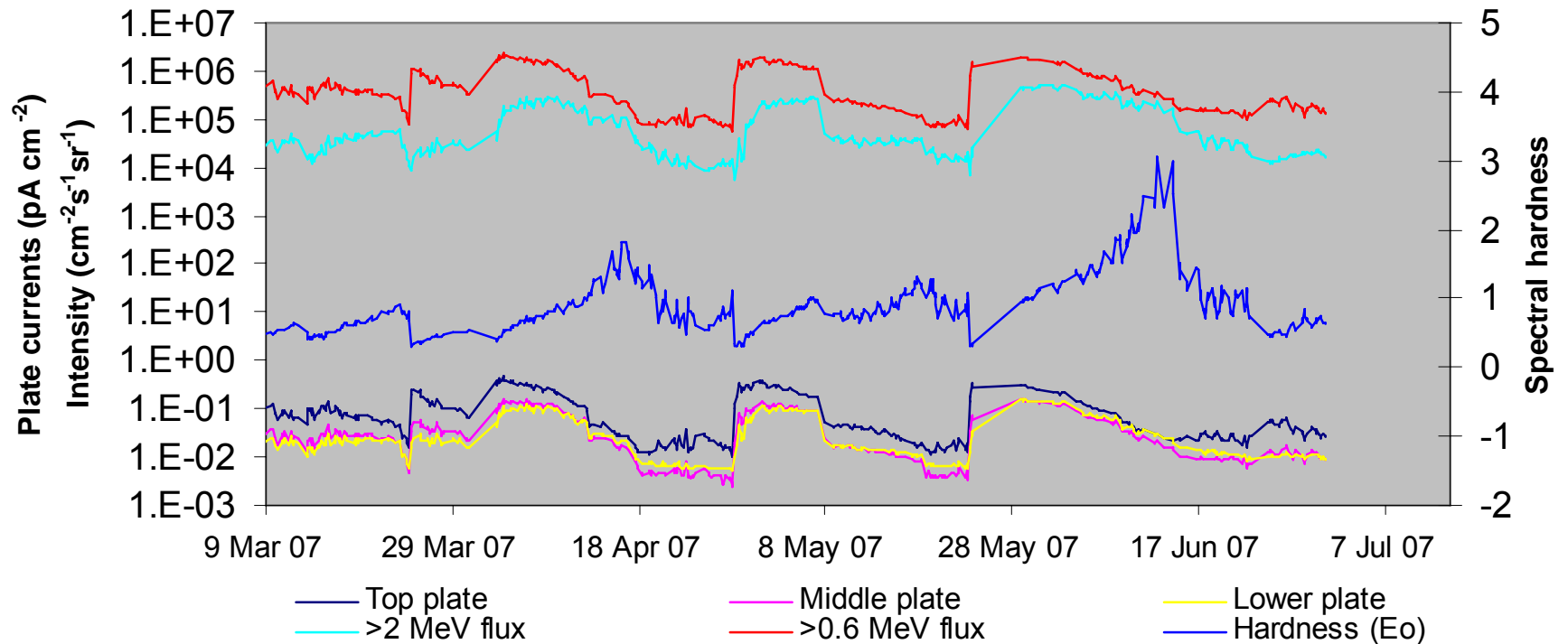

# Comparison with GOES

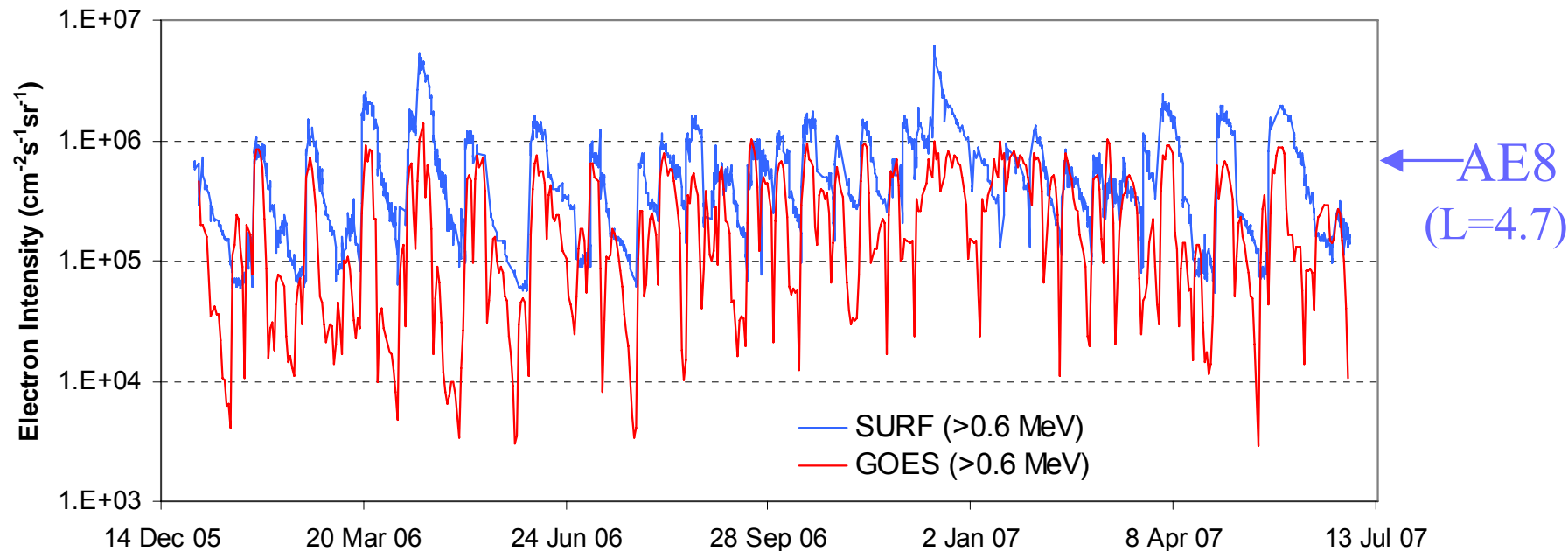

- At  $>0.6$  MeV GEO flux only factor  $\sim 2-4$  lower than MEO

# Comparison with GOES

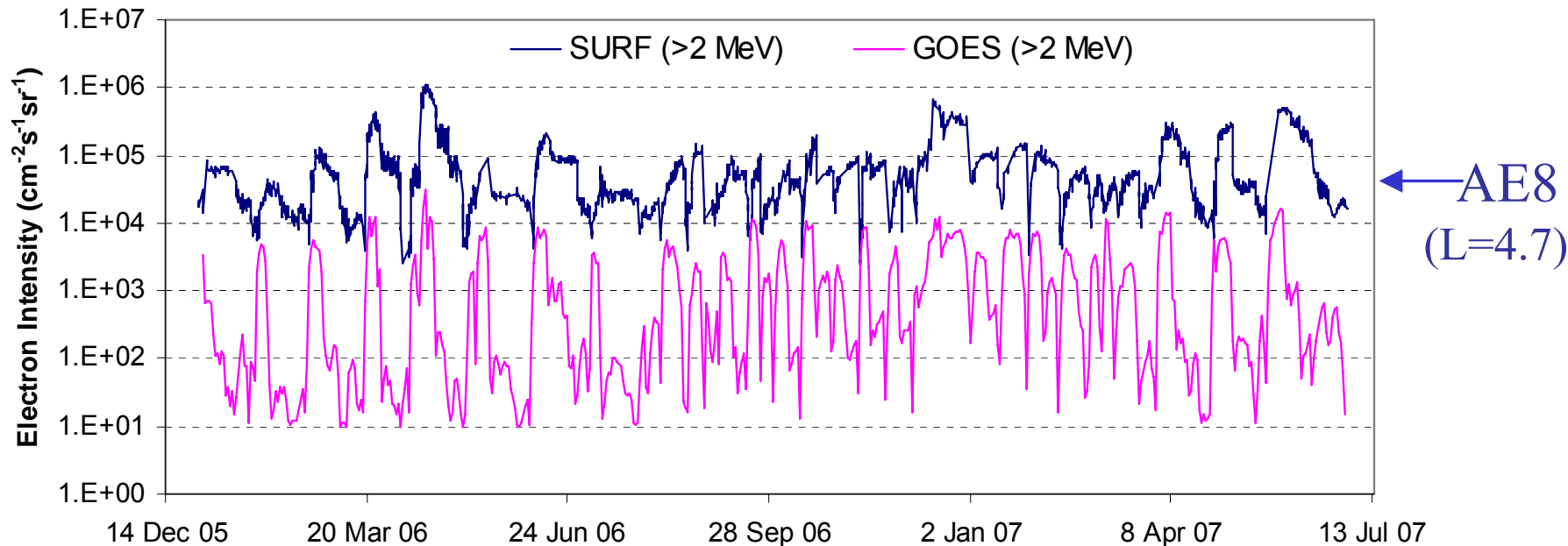

- At >2 MeV GEO flux is substantially reduced c.f. MEO

# GIOVE-A c.f. Van Allen

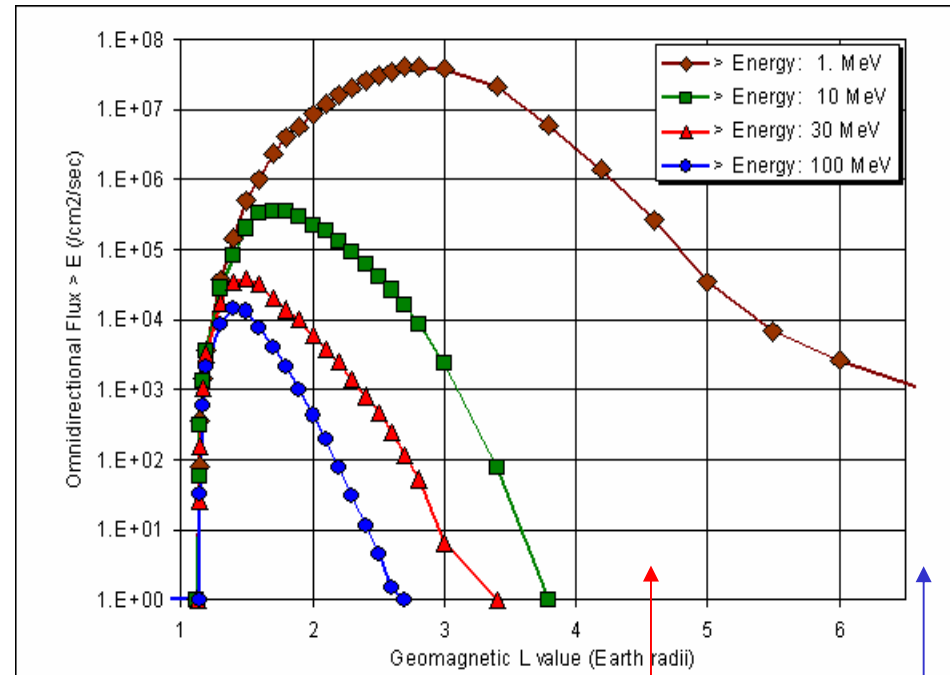
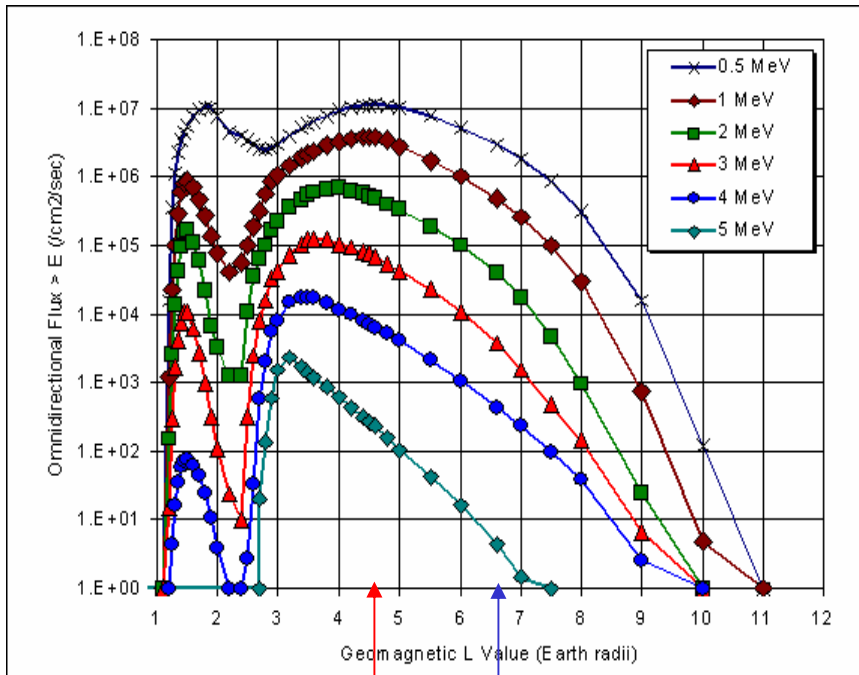

GIOVEA

GEO

GIOVEA

GEO

- Trapped protons low level but...

# What about Solar Protons?

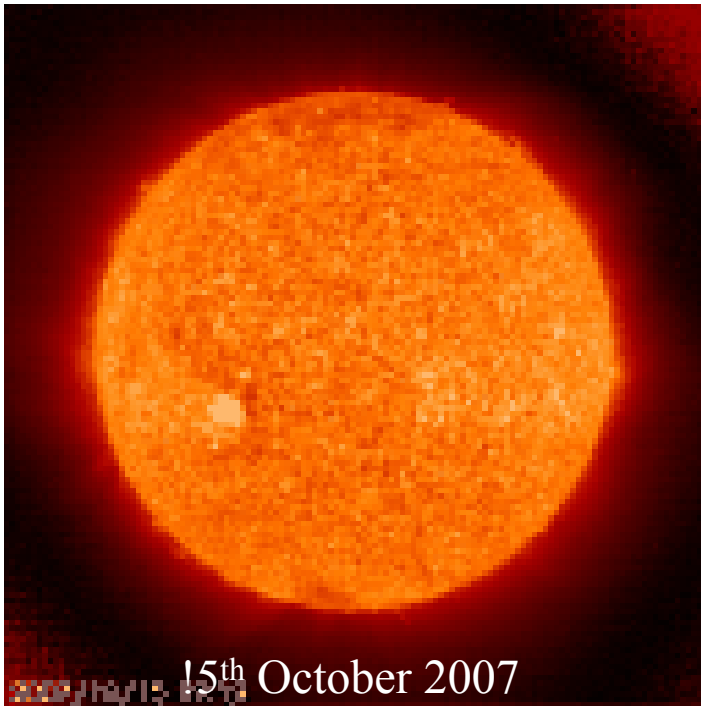

- SPEs associated with Solar Coronal Mass Ejections (CMEs)
- Highly variable in fluence, peak flux, duration, spectral shape & composition

# SPE spectra

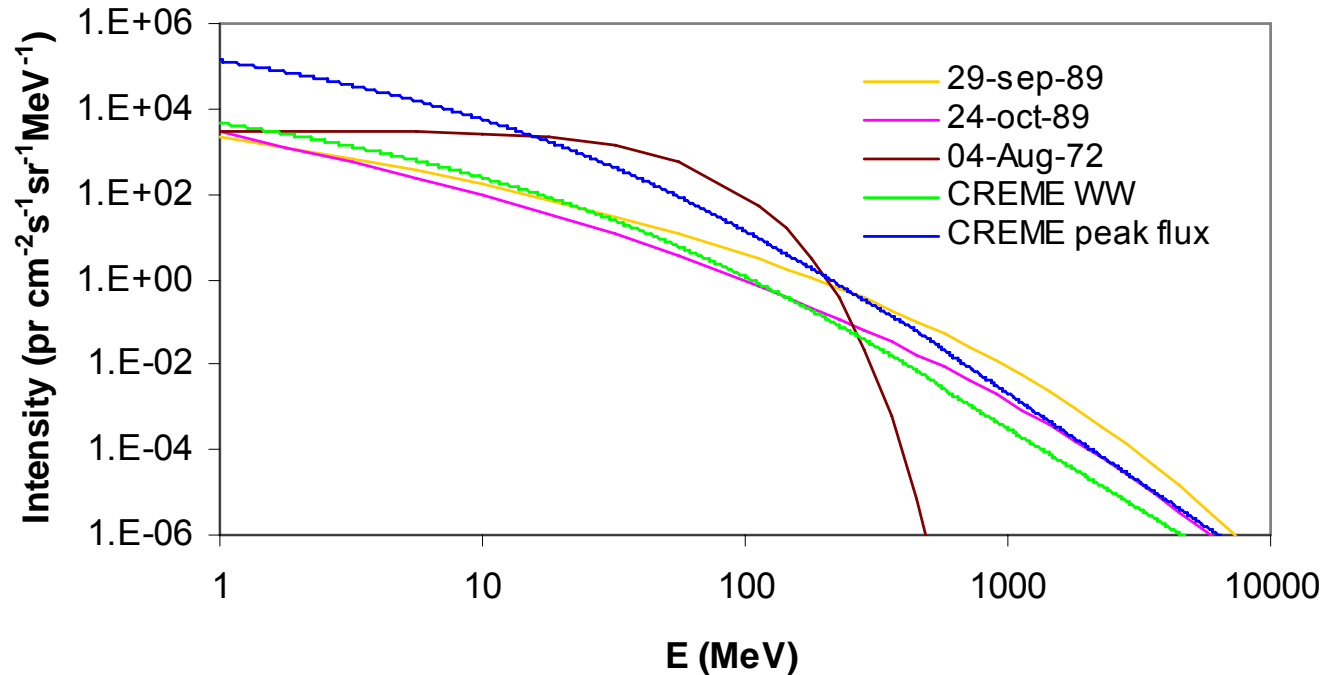

- Need to know SURF proton response functions

# Proton response

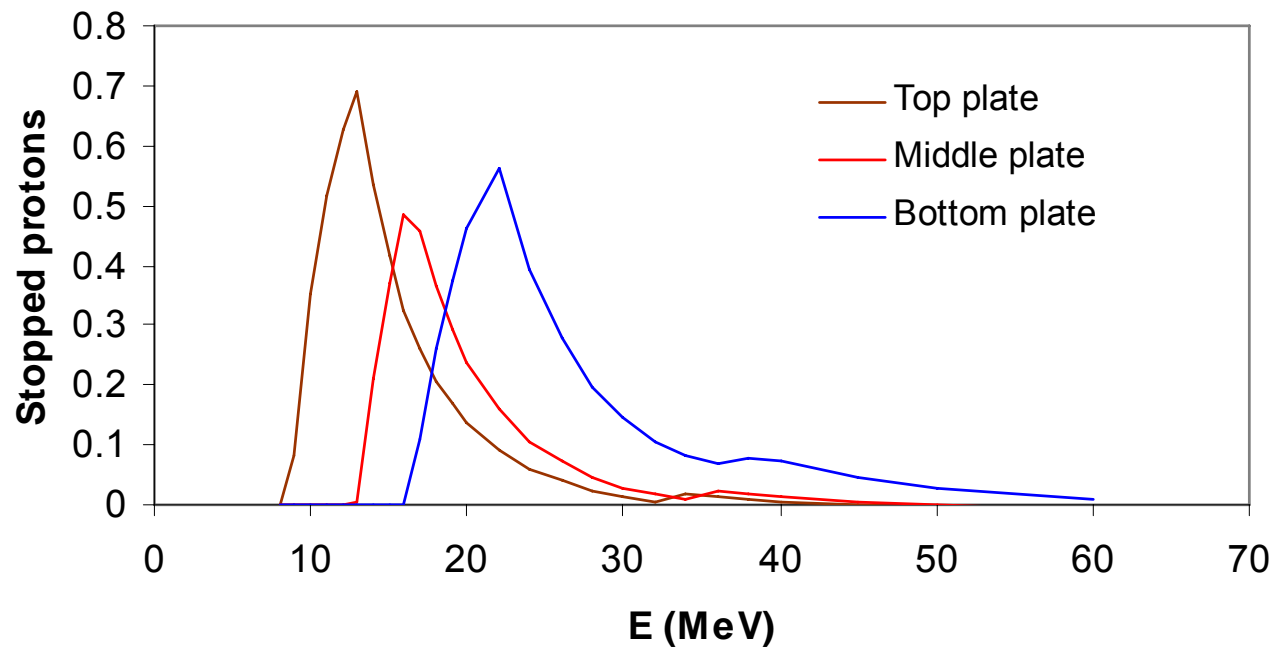

- SURF detects protons in energy range  $\sim 10 < E < 60$  MeV

# 'Positive' current

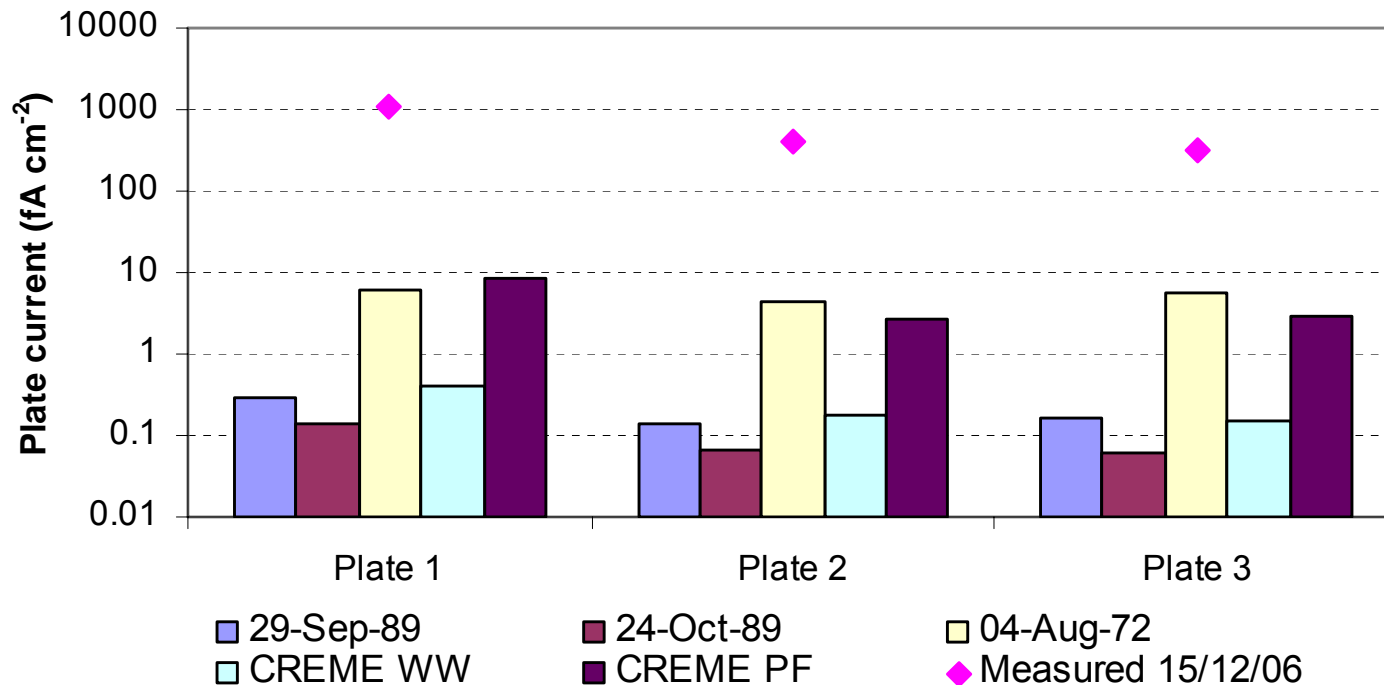

- SPE currents small compared to electron enhancement currents
- Aug 72 represents greatest contamination (why?)

# SPE comparison

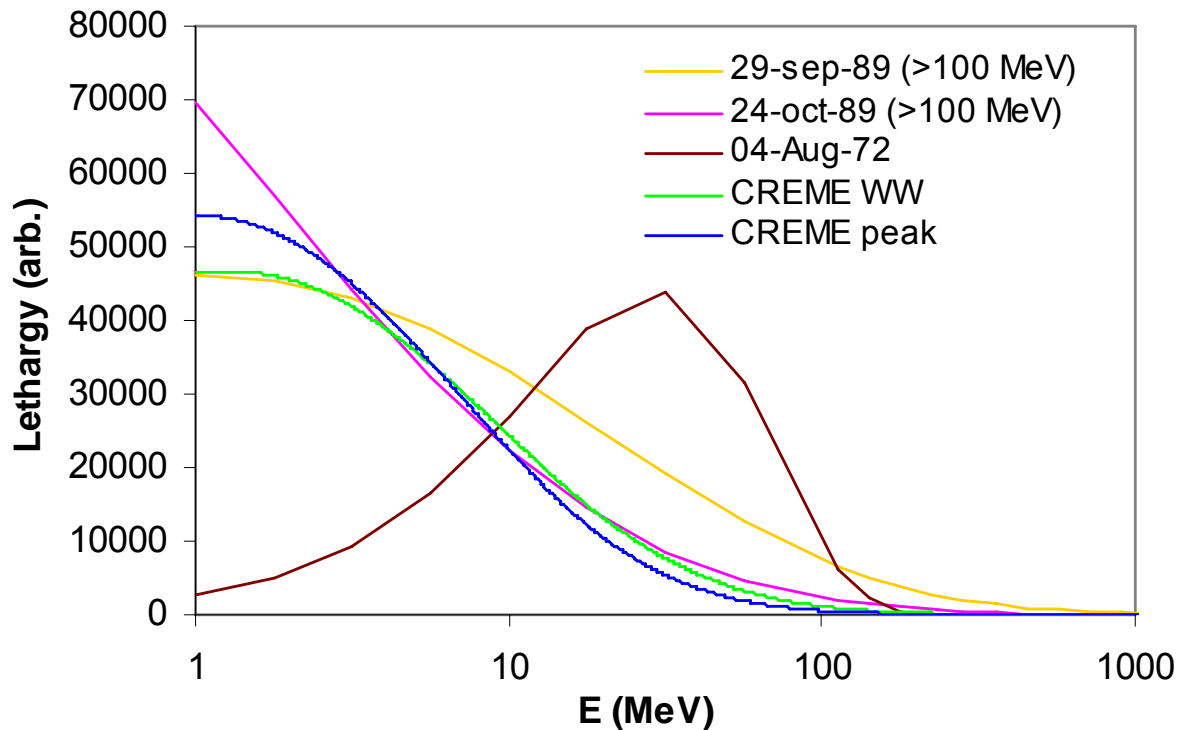

- Aug '72 peak coincides with SURF response peak

# Lower altitude orbits

- For example:  $L=1.6$  ( $\sim$ peak trapped proton intensity)

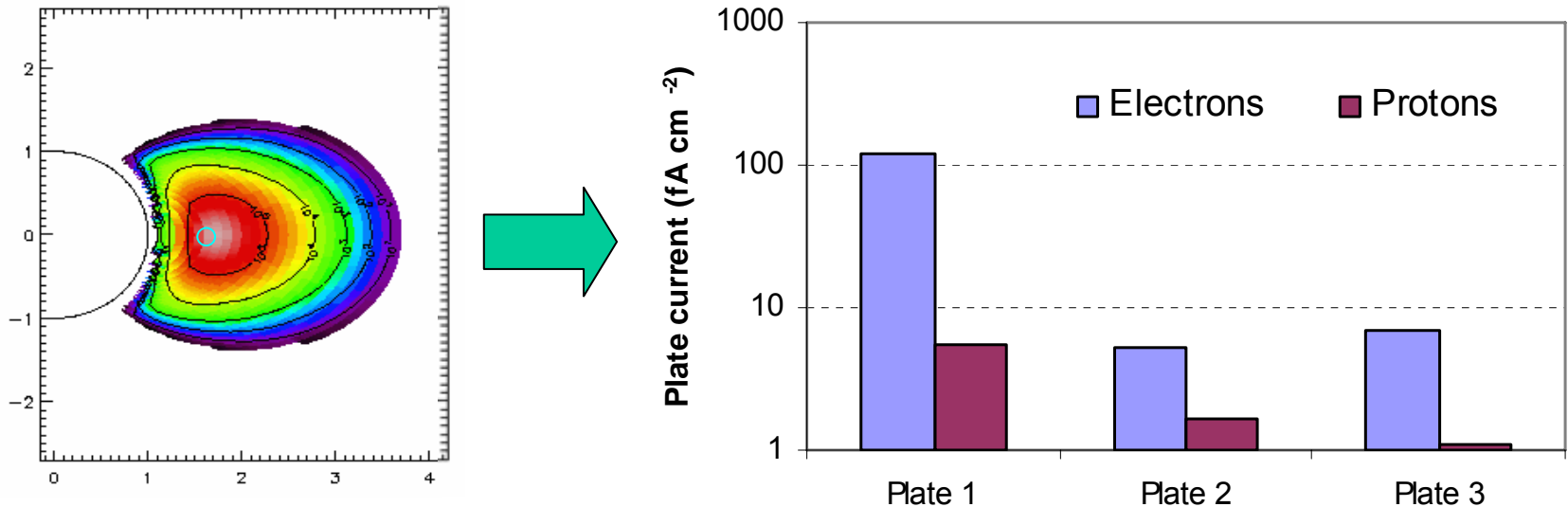

- Proton-induced currents small c.f. electron-induced currents
- Correction can be applied before calculating electron spectrum

# Summary

- Charge collection is an alternative method for measuring high energy electron environment
- SPE protons do not contaminate significantly
- GIOVE-A MEO is beyond high E proton belt but proton currents predicted to be small even at lower orbit altitudes
- Three charging plates offers improved spectral information c.f. two – more would be even better!
- To do: Interpretation of  $B > B_0$  measurements? (region off magnetic equator)